

# NUMBERALL

STAMP & TOOL CO., INC.

## USER MANUAL & PARTS LIST

**MODEL**

**250P**

**1/4" – 3/8" Characters**

**S/N:**

---

## OPTIONAL HOT STAMPING EQUIPMENT

Numberall manufactures hot stamping versions of the Models 70, 80, 83, 85, 23, and 50 Numbering Heads. Due to their hot stamping capabilities, the Model numbers are thereby referred to as Models 270, 280, 283, 285, 223, and 250, respectively. Since field applications and press equipment vary, most hot stamping numbering heads are individually modified to suit customer requirements.

All hot stamping numbering heads are designed to allow for thermal expansion. Various models have unique features to minimize friction and aid in character changes.

The Models 280, 285, and 283 have insulated turning knobs so that the wheel shaft can be rotated. The Model 283 selector knob has holes drilled in it. An insulated pin inserted into the holes allows for rotation of the selector knob.

The Model 250 has rollers on the coil return spring pins to minimize friction. A “pick” is also supplied to preset the wheels. Inserting the “pick” between each wheel and pushing, can individually rotate the wheels.

The hot stamping equipment, when purchased, includes the heating elements, a cord and switch. A temperature controller is not included unless purchased as an option. An overheated numbering head is not covered by warranty, unless wired to our proportional temperature controller. Refer to the catalog and price list for additional options to hot stamping.

### Precautions

The following precautions should be observed when assembling and operating hot stamping equipment:

1. Numberall’s hot stamping numbering heads are designed to operate below 350° Fahrenheit. Operations at higher temperatures can anneal hardened parts and springs and combust insulating handles.
2. At normal operating temperatures, metal parts can burn the skin. Operational procedures and written warnings should be created and posted to protect the operator.
3. Some plastics give off harmful vapors when heated. A thorough knowledge of the materials to be stamped is essential.
4. Enclosed is a canister of special high temperature grease. When cleaning and maintaining the unit, **LIGHTLY** coat the wheel shaft and the outside of the actuating arm with the grease. The grease will improve the operation of

the unit as well as prevent corrosion that can occur with hot stamping units. Do not attempt to lubricate with any other lubricant; some lubricants will break down and leave deposits on the wheels, which can cause the wheels to bind.

5. Allow ample warm up time before stamping. A large mass of metal will heat slowly.
6. Do not attempt to clean a numbering head before disconnecting the power and allowing it to cool. The heating elements, when on, are much hotter than the flash point of most solvents.
7. Protect heater wires and thermocouple leads. These wires are fragile and could easily be broken.
8. Make sure the heaters are mounted well into the frame with no parts exposed. Exposed heater sections will overheat and could damage the element.
9. **A CLEAN HEAD IS A MUST. A MAINTENANCE SCHEDULE MUST BE DETERMINED SO THAT EXCESSIVE DOWNTIME OR DAMAGE CAN BE AVOIDED.**

When ordering parts or obtaining information, always mention the serial number.

If you have any questions or problems our sales department is at your disposal.

# MODEL 250P AUTOMATIC NUMBERING HEAD for 1/4" – 3/8" Characters

## Operating Instructions

1. DO NOT DROP OR ABUSE THE MODEL 250P. The Model 250P is a precision machine; carelessness could damage the pawls or springs.
2. When inserting the Model 250P into the press, make sure the numbering head frame bears the load. The shank aids only to hold the head in the press. Stress should not be applied to the shank. **THE MODEL 250P SHOULD NEVER BE HAMMERED OUT OF THE PRESS.**
3. The actuating arms (50-3-2) should be facing towards the operator for right side up stamping.
4. The wheels in the Model 250P can rotate in only one direction, away from the actuating pawl (50-3-10). Damage to the actuating or retaining pawls can occur if the wheels are forced in the wrong direction.
5. Never attempt to stamp on a surface, unless it is perpendicular along both axes to the Model 250P printing plane. Damage to the actuating or retaining pawls can occur if this warning is not heeded.
6. Make sure that each number wheel is completely indented before stamping. If the wheels are indented properly, they should snap or click back into the indent position after being rotated slightly beyond that position. Stamping with the wheels between indents can damage the actuating or retaining pawls.
7. When adjusting the tripping mechanism, make sure the wheels do not begin to rotate while they are still in contact with the work. In addition to moving the work, rotating the wheels could damage the actuating pawl.
8. When adjusting the tripping mechanism, make sure the actuating arm does not bottom-out on the actuating stop pins. It is possible to shear these pins, possibly damaging the numbering head.

## Marking Instructions

These instructions assume the operator is facing the front side of a press-mounted Model 250P Numbering Head. The actuating pawl (50-3-10) is on the front side. The following procedure adjusts the numbering head to stamp consecutive numbers beginning with the number one.

It is possible to stamp consecutive numbers in two forms. The zeros preceding a number may be included or excluded. For example, the number 25 may be stamped as 000025 or as 25.

### **Including Zeros**

These instructions include the zero preceding a number.

1. Using the “pick” supplied with the Model 250P, rotate the unit wheel, which is the right most wheel, by inserting the pick between the wheel and pushing on the index plate. Rotate it away from the actuating pawl (50-3-10) until the number 1 is at the bottom.
2. Rotate the other wheels away from the actuating pawl until the number zero is at the bottom.
3. If the tripper assembly and the press are properly adjusted, the Model 250P is ready to stamp consecutive numbers.

### **Excluding Zeros**

These instructions exclude the zeros preceding a number.

1. The unit wheel is the right most wheel. Rotate it away from the actuating pawl (50-3-10), until the number one is at the bottom.
2. Rotate the other wheels away from the actuating pawl, until the number zero is at the bottom.
3. Further rotate the wheels, except the unit wheel, slowly until it snaps into the next indent. At this wheel position a recessed space is downward and hence, no impression will be made. As the consecutive number increases, each wheel will still advance at the proper time.

### **Disassembly Instructions**

The following directions assume the numbering head is resting with the front side up and the frame legs toward the operator. The actuating pawl (50-3-10) is on the front side. The Model 250P can be disassembled in any convenient position, but the directions are for a head in the above location.

1. Choose a clean bench to disassemble the Model 250P.
2. **CAUTION: Wear safety glasses when disassembling the Model 250P.** Springs, which are part of the head, could fly out during disassembly and cause eye injury.

3. Remove the loops of the left and right coil return springs (50-3-6) from the left and right coil return spring pins (50-3-7). **CAUTION:** These springs are under considerable tension and should be handled carefully.
4. Loosen both left and right coil return spring screws (50-3-8) and remove the springs from the arm bar (50-3-3).
5. Twist a piece of flexible wire around the actuating arm cross head (50-3-2) and the actuating pawl (50-3-10). Pull the actuating pawl far enough toward the cross head, so that it clears the wheels. Take care not to damage your fingers.
6. Remove the three machine screws that hold the retaining pawl spring (50-3-25). Mark the outside of the spring before removing it.
7. It is not necessary to remove the pawl block (50-3-23) in order to remove the wheels.
8. Remove both wheel shaft set screws. Pull the retaining pawls (50-3-21) away from the wheels.
9. Slowly push the wheel shaft (50-3-18) out of the frame (50-3-1). Take care not to drop the wheels or the actuating arm. Maintain the original wheel order for proper assembly. The actuating arms should be treated with care. If it is twisted, re-assembly may not be possible.

### **Removing the Pawl Block (50-3-23)**

1. Remove the two pawl block screws (50-3-24). The pawl block (50-3-23) should lift out. The pawl block fits tightly in the frame and it may be necessary to tap it. Care should be taken not to bend the retaining pawls (50-3-21) or the retaining pawl shaft (50-3-22).
2. If the retaining pawls are to be removed, maintain the original order for re-assembly.

### **Removing the Actuating Pawl (50-3-10)**

1. While holding the actuating pawl (50-3-10) to keep it from rotating, remove the twisted wire.
2. Allow the actuating pawl to slowly rotate, relieving spring torque, until it strikes the cross head.
3. Unscrew the actuating pawl shaft (50-3-9) from the arm, while holding the actuating pawl spring (50-3-17) above and below with two fingers. Remove

the actuating pawl shaft, be careful not to drop the actuating pawl. The spring is under tension and could fly out.

## Assembly Instructions

1. When assembling the Model 250P make sure all surfaces are free of dirt and grit.
2. **CAUTION: Always wear safety glasses when assembling the Model 250P.** The springs to be assembled are under tension and could cause eye injury.
3. The following directions assume the numbering head is resting with the front side up and the frame legs toward the operator and the pawl block mill cut is on the rear side.
4. If the actuating pawl is already assembled in the actuating arm, skip instructions 5 through 16.
5. Cut a pin slightly shorter than the outside width of the actuating pawl and small enough in diameter to slip through the actuating pawl and shaft holes.
6. Position the actuating pawl with the flat surface up and the legs toward the operator. Start the pin from the left hand side through the hole in the leg and halfway across the space between the legs.
7. Slip the actuating pawl spring (50-3-17) over the pin in such a way that the right angle bend in the spring leg mates with the right angle surfaces between the legs.
8. Rotate the other leg of the spring in the direction of increasing spring torque, until it catches on the side of the pawl block opposite the flat side.
9. Push the pin completely through the spring and into the opposite leg of the actuating pawl.
10. Make sure the pin is not longer than the width of the actuating pawl.
11. Position the actuating arm with the arm bar in a horizontal position and the straight edges of the arm legs facing down.
12. Slide the actuating pawl in between the arm legs, with the actuating pawl prongs pointing toward the arm bar and the actuating pawl spring down.
13. The actuating pawl must be moved in this position toward the arm bar until the holes in the actuating pawl align with the actuating pawl shaft holes in the arms. As the pawl is moved toward the arm bar, the spring leg, which extends

toward the arm bar, must be rotated in the direction of increasing spring torque and forced against the flat surface between the actuating pawl shaft holes.

14. After aligning the holes in the arm and the pawl, start the threaded end of the actuating pawl shaft (50-3-9) through the aligned holes. Carefully force the pin out of the actuating pawl spring with the actuating pawl shaft. Ease the spring onto the shaft as it is advanced. Some models have a spacer between the actuating pawl and the actuating arms.
15. Securely tighten the actuating pawl shaft.
16. Rotate the actuating pawl in the direction of increasing spring tension until it reaches a stop. Using flexible wire, fasten the actuating pawl to the actuating arm cross head.
17. Slide the actuating arms between the frame legs. The straight edge of the arm will be up.
18. Start the wheel shaft (50-3-18) through the frame leg from the right. Align the right actuating arm and advance the shaft through the arm and halfway across the space between frame legs.
19. Slide the wheels onto the shaft in the original order, advancing the shaft when necessary. Make sure to remove any burrs on the wheels or actuating arms. Use a medium India stone to remove burrs. **CAUTION:** the actuating arms are chrome plated and should not be stoned more than is necessary. The indent side of the wheels goes on the right.
20. The wheel shaft ends should be flush with the frame sides. Align the flats on the shaft with the set screws (50-3-20) in the frame legs. Securely tighten the set screws.
21. Turn the frame over with the retaining pawl block mill cut facing up and the frame legs toward the operator. If the retaining pawl block is in place skip instructions 22 through 24.
22. Slide the retaining pawls (50-3-21) onto the retaining pawl shaft (50-3-22) in their original order. The working end of the unit wheel pawl is wider than the other pawls and must be placed in the proper position.
23. Rest the retaining pawl block with the milled cut facing up and toward the operator. Rest the retaining pawls with the shaft next to the milled cut and the flat pawl ends up and toward the operator.
24. Mate the retaining pawls with their respective slots. Position the shaft in the milled cut with its end flush with the pawl block ends.



25. Holding the pawls into their slots, turn the pawl block over and insert it into the milled cut in the frame. Make sure each pawl rests in between each wheel.
26. Evenly tighten the pawl block screws (50-3-24). Make sure the pawls do not bind. They should work freely.
27. Position the retaining pawl spring (50-3-25) over the retaining pawls with the original side out. The spring is not symmetrical and thus is only correctly assembled one way. The spring "fingers" should align with the retaining pawl centers.
28. Evenly tighten the retaining pawl spring screws.
29. Rest the frame with the front side up and the frame legs toward the operator as in instruction 3.
30. Slide the right coil return spring (50-3-6) onto the arm bar (50-3-3). Determine which is the right spring as follows: when viewed from the loop end, the loop will be on the right hand side of the spring. **NEVER** interchange springs from different Model 250P Numbering Heads.
31. Secure the inside end of the spring by tightening the coil spring return screws (50-3-8).
32. Rotate the spring loop in the direction of increasing spring torque and slide the loop over the coil return spring pin (50-3-7). **CAUTION:** The springs will be under considerable torque and could rotate rapidly if released.
33. Repeat steps 30, 31, and 32 for the left coil return spring.
34. Remove the flexible wire holding the actuating pawl.
35. By hand, rotate each wheel away from the actuating pawl until they indent. The Model 250P wheels will only rotate in one direction. **DAMAGE** to the pawls can occur if they are forced in the opposite direction.
36. Check the operation of the Model 250P Numbering Head. The actuating arm should operate smoothly without any binding.

## **Recommended Spare Parts for Model 250P**

- 1 Set Coil Return Springs (50-3-6) (Not required with Air-Trip)
- 1 Actuating Pawl (50-3-10)
- 1 Actuating Pawl Springs (50-3-17)
- 2 Retaining Pawls (Regular) (50-3-21)
- 1 Retaining Pawl (Unit) (50-3-21)
- 1 Retaining Pawl Spring (50-3-25)
- Spare wheels should be stocked depending on use and the material being stamped.

## OPTIONAL AIR-TRIPPING ATTACHMENT

An air-tripping attachment is available for the Model 250P Automatic Numbering Machine. This system is advantageous where press design or space limitations makes mechanical tripping cumbersome.

Basically two small air cylinders mounted to the numbering machine, are used to move the actuating arms, which move the wheels to the next number. A miniature roller valve, activated by the movement of the press ram, controls air flow to the cylinders. The mechanism works on the up-stroke of the press. Also included is an adjustable speed control valve.

An air/logic control can be supplied which will repeat the same number up to 24 times before allowing the air cylinders to trip the unit.

The air-tripping system is designed for 60-80 psi. The cylinders and air plumbing attached to the numbering machine come pre-assembled.

### Precautions

The following precautions should be observed when assembling and operating the air-tripping attachment:

1. The actuating arm bar moves very rapidly when the air cylinders extend. Keep both hands completely free of that area.
2. The air-tripping system is designed to operate with a 60-80 psi air supply. A filtered line is recommended to prevent any contamination.
3. The machine screws that secure the cylinder mounting bars to the frame must remain tight. They are assembled at the factory using a thread sealant, but should be periodically checked.
4. The tubing supplied with the tripping assembly is 1/8" nylon. All tubing fittings are the compression type and do not require hollow cores because of the small tubing diameter.
5. The standard air cylinder is single acting and spring returned. It has a bumper system to cushion the end of the stroke. If the numbering machine is used for hot stamping, a heat resistant bumper is required. The air cylinders **DO NOT REQUIRE LUBRICATION.**

## Adjustments

The following instructions have been done at the factory prior to shipping. However, if it is necessary to disassemble, the following adjustments may have to be performed.

1. Adjust the length of the air cylinder rods so that they push evenly. Otherwise the resulting twisting motion can bind the numbering machine. The rods have been adjusted prior to shipping.
2. Do not over-tighten the shoulder screw, which secures the base of the air cylinder. If over-tightened, the cylinder may bind. Also, the threads of the shoulder screw must be sealed, since they extend into the air chamber. This is done at the factory prior to shipping.
3. The travel of the air cylinders must be adjusted so that the numbering machine indents (or clicks) at the end of the cylinder stroke. There are no positive stops for the actuating arms in the Model 250P Numbering Machines that are factory equipped with air tripping.

## Assembly Instructions

The following general instructions apply to assembling the air-tripping attachment. Since many options are available and most press installations are customized, no detailed directions are available.

1. Mount the numbering machine to the press.
2. Design and mount a bracket for the miniature roller valve, so that the ram will activate the valve on the upstroke. Make sure the valve does not open before the numbering machine leaves the material surface. Bearing on the roller or directly on the valve button can activate the valve.
3. Assemble the tubing so that the air flows from the supply through the valve and to the air cylinders. Make sure the air lines are protected from the press. Check all fittings, they should be air tight.
4. Adjust the length of the piston rods so that the numbering wheel clicks into position just as the cylinders reach the end of the stroke. Loosening the jam nut and rotating the piston rod adjust the piston rod. Tighten the jam nut after adjustment. **THIS HAS BEEN DONE PRIOR TO SHIPPING, SO ADJUSTMENT MAY NOT BE REQUIRED.**
5. Adjust the press so that the Model 250P numbering machine will clear the table at all times during the ram stroke.

6. Crack the adjustable speed control open and cycle the press. Keep both hands completely clear of the table area when operating the press. If the piston rods fail to fully advance the actuating arms, advance the wheel manually to the next indent. Open the speed control further and cycle the press. Continue this process until the numbering machine advances properly. If the piston rods push unequally, adjust the lengths as per the previous instructions.

If you have any problems or require additional instructions, please contact our sales office. When calling always provide the serial number.

# NUMBERALL

STAMP & TOOL CO., INC.

BOX 187, HIGH ST.,  
SANGERVILLE, ME 04479

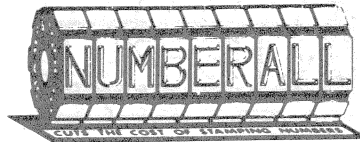

(207) 876-3541 FAX: (207) 876-3566

## Model 50 Automatic Numbering Machines PARTS LIST

### Model 50 Automatic Numbering Machines

#### PARTS LIST

For 1/4" Through 3/8" Character Sizes

50-3-1	Frame Refer to Factory for Replacement
50-3-2	Actuating Arms (w/Cross Head & A. Pawl Shaft)
50-3-3	Arm Bar
50-3-4	Actuating Arms Stop Pins (2 req'd)
50-3-5	Actuating Arm Stop Pin Screws (2 req'd)
50-3-6	Coil Return Spring (2 req'd)
50-3-7	Coil Return Spring Pins (2 req'd)
50-3-8	Coil Return Spring Screws (2 req'd)
50-3-9	Actuating Pawl Shaft
50-3-10	Actuating Pawl (Std. 4 or 6 Wheels)
50-3-17	Actuating Pawl Spring
50-3-18	Wheel Shaft (standard)
50-3-19	Wheel Shaft (Model 250, hollow)
50-3-20	Wheel Shaft Set Screws (2 req'd)
50-3-21	Retaining Pawls (reg. or unit)
50-3-22	Retaining Pawl Shaft
50-3-23	Pawl Block
50-3-24	Pawl Block Screws (2 req'd)
50-3-25	Retaining Pawl Spring
50-3-25A	Retaining Pawl Spring Screws
50-3-26	Wheels (as per price list, specify Reg. or Unit)
50-3-32	Hot Stamping (Electrical Parts Assembly)
50-3-33	Heater
50-3-34	Cord and Switch
50-3-35	Coil Spring Protector
50-3-36	Insulation (Plastic & Fibre Glass)
50-3-37	Coil Return Spring Rollers (2 req'd)
50-3-38	Coil Return Spring Roller Screws (2 req'd)
50-3-39	Air Trip Mechanism (complete)
50-3-40	Air Trip Mechanism Cylinders (2 req'd)
50-3-41	Air Trip Mechanism Cylinders Heat Resistant
50-3-42	Air Cylinder Mounting Bars (2 req'd)
50-3-43	Air Cylinder Mounting Screws (2 req'd)
50-3-44	Air Cylinder Mounting Bar Screws (4 req'd)
50-3-45	Air Brass Fittings (6 req'd)
50-3-46	Air Speed Control
50-3-47	Air Valve
50-3-48	Air Valve Roller Actuator
50-3-49	Air Valve/Speed Control Mounting Bracket
50-3-50	Teflon Tubing

# NUMBERALL

STAMP & TOOL CO., INC.

BOX 187, HIGH ST.,  
SANGERVILLE, ME 04479

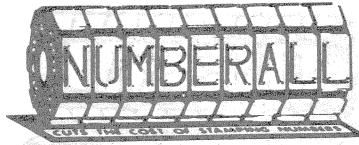

(207) 876-3541 FAX (207) 876-3566

## Model 50 Numbering Machine

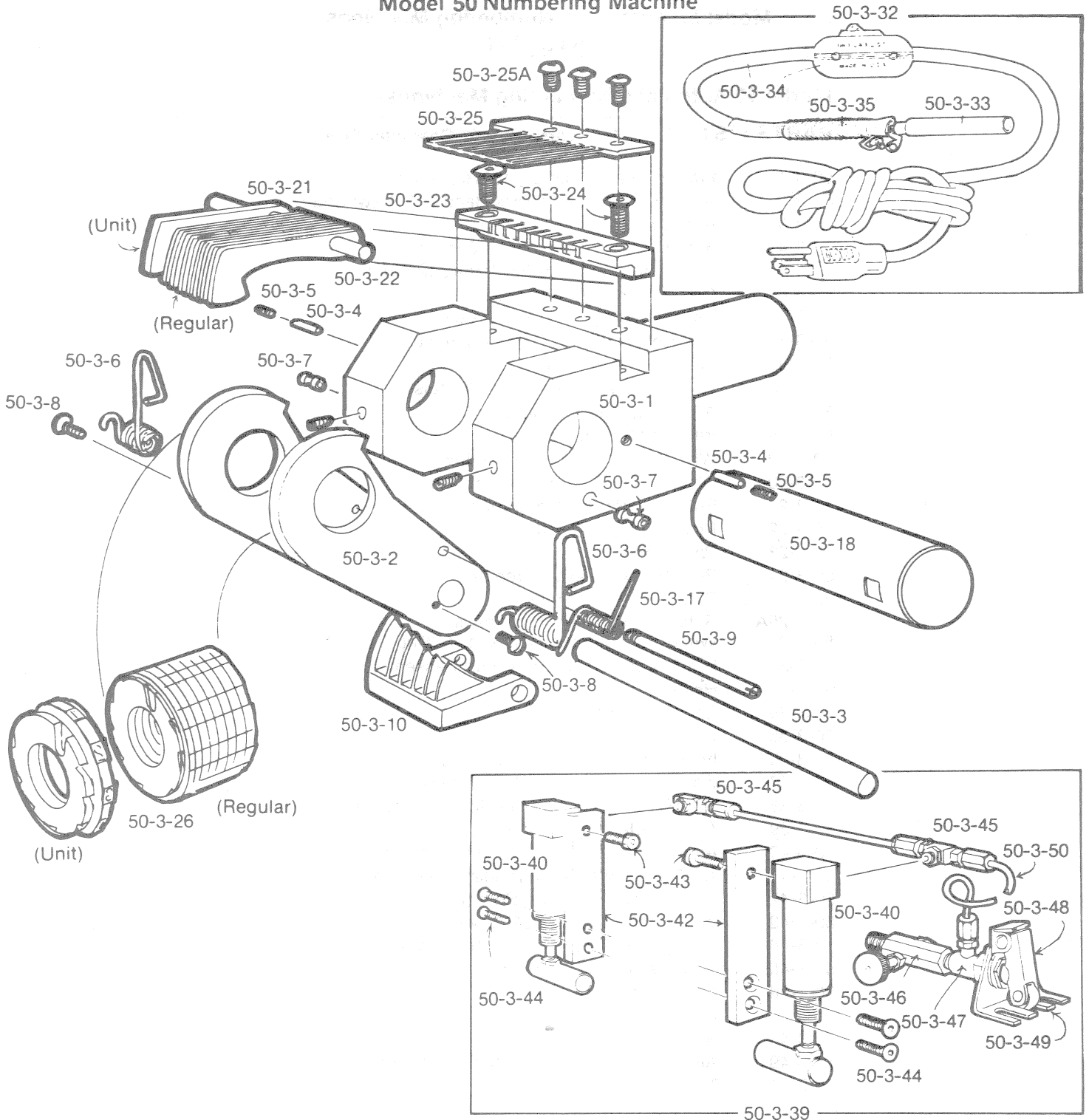

**ALWAYS SPECIFY SERIAL NUMBER WHEN ORDERING PARTS.**

**Numberall Stamp & Tool Co., Inc.**

For extra copies of this manual please call or  
visit our website.