

NUMBERALL

STAMP & TOOL CO., INC.

USER MANUAL & PARTS LIST

MODEL

85

5/32" – 1/4" Characters

S/N:

P.O. BOX 187, 1 HIGH ST.
SANGERVILLE, ME 04479

www.numberall.com
office@numberall.com

TEL: 207-876-3541
FAX: 207-876-3566

MODEL 85 2 WHEELS QUICK-CHANGE HEAD for 5/32” – 1/4” Characters

Operating Instructions for Hand Shank Models

- 1. CAUTION: ALWAYS WEAR SAFETY GLASSES WHEN STRIKING SHANK WITH A HAMMER BLOW.**
2. DO NOT DROP OR ABUSE THE MODEL 85. Carelessness could damage the retaining pawls or retaining pawl spring. Always lay the unit on its front side, with the retaining pawl spring facing up.
3. The wheels are rotated by means of sliding the wheel shaft against the frame, and rotating either the left or right-hand knurled knob (85-175-9). The wheels can be rotated in either direction. By sliding the wheel shaft to the left, the “tens” wheel can be rotated. By sliding the wheel shaft to the right, the “ones” or “unit” wheel can be rotated. A spanner wrench is used to rotate the remaining wheels. The raised base of each character pad provides a step for the spanner wrench to grab.
4. When rotating the wheels to a new character, make sure the retaining pawl is in the detent position.
5. The front of the Model 85 is the side on which the Numberall logo is stamped. This side should be toward the operator when stamping.
6. After aligning the Model 85 with your work, strike the shank with a hammer blow. The size of the hammer and the force of the blow control the depth of impression.
7. **LIGHTLY LUBRICATE THE MODEL 85.** Keep the wheels and parts free from dirt and grit. The clearances are very tight and accumulated dirt, grit or oil may bind the machine.
8. On Model 85 machines, with the wheels indexed for direct sight-reading, the stamped character sequence can be read by reading the sequence that is depicted by the arrows that are stamped on the frame. The arrows point towards characters that will do the stamping. This is the sequence that is to be stamped. The arrows are located so that a person sitting down can read the indexing correctly.

Operating Instructions for Press Models

1. When inserting the Model 85P in the press, make sure the frame bears the load. The shank should serve only to locate the Model 85P and keep it from falling out. No load should bear on the shank.
2. The front of the Model 85P is the side with the Numberall logo stamped on it. This should be facing the operator or towards the front of the press (depending on the orientation of the work to be stamped).
3. Follow the following instructions listed above: Steps 2, 3, 4, 7, and 8.

Disassembly Instructions

1. When ordering parts or requesting information, ALWAYS refer to the numbering head's serial number stamped on the right-hand side of the frame.
2. Select a clean bench that is free of dirt and grit to disassemble the Model 85.
3. Remove the pawl block machine screws (85-175-16) on the back of the unit. Then remove the pawl block cover plate (85-175-15).
4. Remove the retaining pawl spring (85-175-17). When removing, mark the outside of the spring so that it is not re-assembled incorrectly.
5. Remove the pawl block (85-175-14).
6. Remove the set screw that is holding the left-hand knurled knob (85-175-9) to the wheel shaft (85-175-5). Remove the knob.
7. Turn the right-hand knurled knob until the set screw in the knob is pointing towards the rear of the machine. This will align a 1/16" diameter pin on the wheel shaft with the frame keyway.
8. Slowly and easily slide the wheel shaft out of the numbering head to the right. The pin will have to pass through some of the numbering wheels, the side washer (85-175-11) and the right-hand frame leg. It may be necessary to rock the shaft slightly in order to work the pin through. Maintain a record of the wheel order for re-assembly.

Replacing Retaining Pawls

1. Disassemble the marking head as per above Disassembly Instructions.

2. Using the flat of the spanner wrench, carefully push the retaining pawl shaft (85-175-13) and retaining pawls (85-175-12) out of the slot in the pawl block (85-175-14). Do not bend the retaining pawls.
3. Maintain the original positioning of the retaining pawls, slide the pawls off the shaft.
4. Replace the retaining pawls as necessary and slip all of the retaining pawls onto the shaft in the original order.
5. Align the retaining pawls on the shaft so that they drop into the milled slots. Position the shaft left and right so it clears the screw holes.
6. Press the retaining pawl shaft into its slot until it bottoms. The shaft must rest on the bottom of the slot.
7. On rare occasions, when a new retaining pawl is combined with a used wheel, a very slight misalignment of the wheel, relative to the other wheels can occur. This can be corrected by honing the radius of the pawl. The radius of the pawl must remain unchanged, while the center of the radius is moved slightly. Care must be exercised not to remove too much metal; otherwise the spring tension on the retaining pawl will be reduced.
8. Factory-trained personnel can easily replace retaining pawls, so it is recommended that the numbering head be returned for service if you have difficulty with this process.

Assembly Instructions

1. Make sure the surfaces of the character wheels and parts are clean. **USE A LIGHT LUBRICANT.**
2. Start the wheel shaft (85-175-5) into the right-hand side of the frame (85-175-1). Make sure the set screw of the knurled knob is positioned to the rear.
3. Slide the wheel shaft part way into the frame opening. Beginning with the side washer (85-175-11), push the washer and then the wheels in the original order, onto the wheel shaft. The index plate side of the wheels should be against the side washer. NOTE: The “ones” or “units” wheel and the “tens” wheel are the only wheels with a broached spline. These wheels must go on after the side washer, or the Model 85 cannot be assembled.
4. After all of the wheels are in place, push the wheel shaft further left until it protrudes from the frame. It may be necessary to rock the wheel shaft to help slide through the wheels and frame leg. **DO NOT FORCE.**

5. Slide the left-hand knurled knob (85-175-9) onto the wheel shaft. The knurled part of the knob goes toward the outside. Position the outside edge of the knob exactly flush with the end of the wheel shaft. Align the set screw with the flat on the wheel shaft. Securely tighten the set screw.
6. Turn the numbering head over, with the pawl block mill cut facing up and the frame legs facing toward the operator.
7. Place the pawl block (85-175-14), with the retaining pawls and shaft in place, into the mill cut. The semi circular ends of the retaining pawls should be facing down. Make sure each retaining pawl (85-175-12) rests in its own slot.
8. Place the retaining pawl spring (85-175-17) over the pawls so that the spring tines are centered above each pawl (the marked side of the spring should be facing out).
9. Place the pawl block cover plate (85-175-15) over the spring and evenly tighten the pawl block screws (85-175-16). Make sure the pawl block is seated in the mill cut.
10. After tightening the machine screws, rotate each wheel. Every wheel should positively indent without any binding or rocking.

Recommended Spare Parts

- 1 Side Washer (85-175-10)
- 2 Retaining Pawls (85-175-12)
- 1 Retaining Pawl Spring (85-175-17)
- 1 Spanner Wrench (85-175-37)
- Spare Wheels should also be stocked, depending on use and the material being stamped.

NUMBERALL

STAMP & TOOL CO., INC.

BOX 187, HIGH ST.,
SANGERVILLE, ME 04479

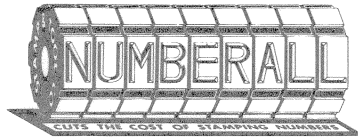

(207) 876-3541 FAX: (207) 876-3566

Model 85 2-Wheel Quick-Change Numbering Machine

PARTS LIST

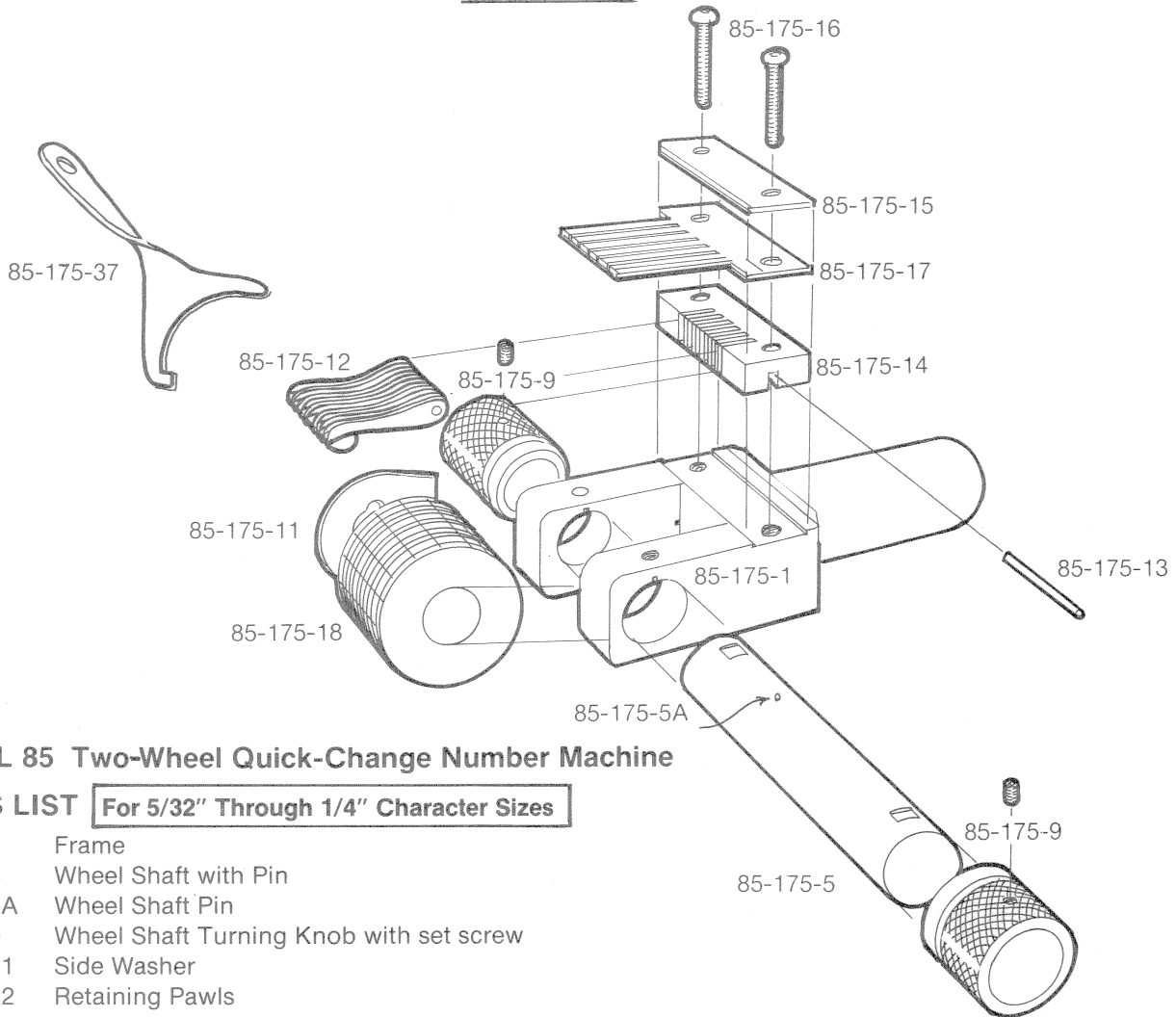

MODEL 85 Two-Wheel Quick-Change Number Machine

PARTS LIST For 5/32" Through 1/4" Character Sizes

- 85-175-1 Frame
- 85-175-5 Wheel Shaft with Pin
- 85-175-5A Wheel Shaft Pin
- 85-175-9 Wheel Shaft Turning Knob with set screw
- 85-175-11 Side Washer
- 85-175-12 Retaining Pawls
- 85-175-13 Retaining Pawl Shaft
- 85-175-14 Pawl Block
- 85-175-15 Pawl Block Cover Plate
- 85-175-16 Pawl Block/Cover Plate Screws (2 required)
- 85-175-17 Retaining Pawl Spring
- 85-175-18 Wheels Non Quick Change (refer to price list)
- 85-175-20 Wheels Quick Change (refer to price list)
- 85-175-22 Blank Spacers
- 85-175-26 Hot Stamping Equipment
- 85-175-28 Heating Element
- 85-175-29 Cord & Switch
- 85-175-30 Coil Spring Protector
- 85-175-37 Spanner Wrench

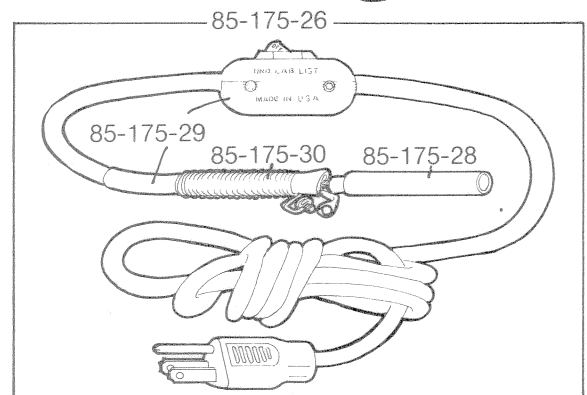

ALWAYS SPECIFY SERIAL NUMBER WHEN ORDERING PARTS.

Numberall Stamp & Tool Co., Inc.

For extra copies of this manual please call or
visit our website.