

# Closed End Punch Strippers

Closed End Urethane Strippers assure positive stripping and at the same time dampen punch vibration by gripping around the punch point. Since vibration can lead to premature punch failure, using DAYTON PROGRESS Urethane Strippers will increase overall punch life. The closed end feature holds thin stock flat during the stripping cycle, eliminating the problem of damaging the stock strip.

## And that's not all...

Because of a unique curing agent, DAYTON's Urethane Strippers develop more load-bearing capacity than similar urethanes. This special curing agent also contributes to consistent pressure ratings.

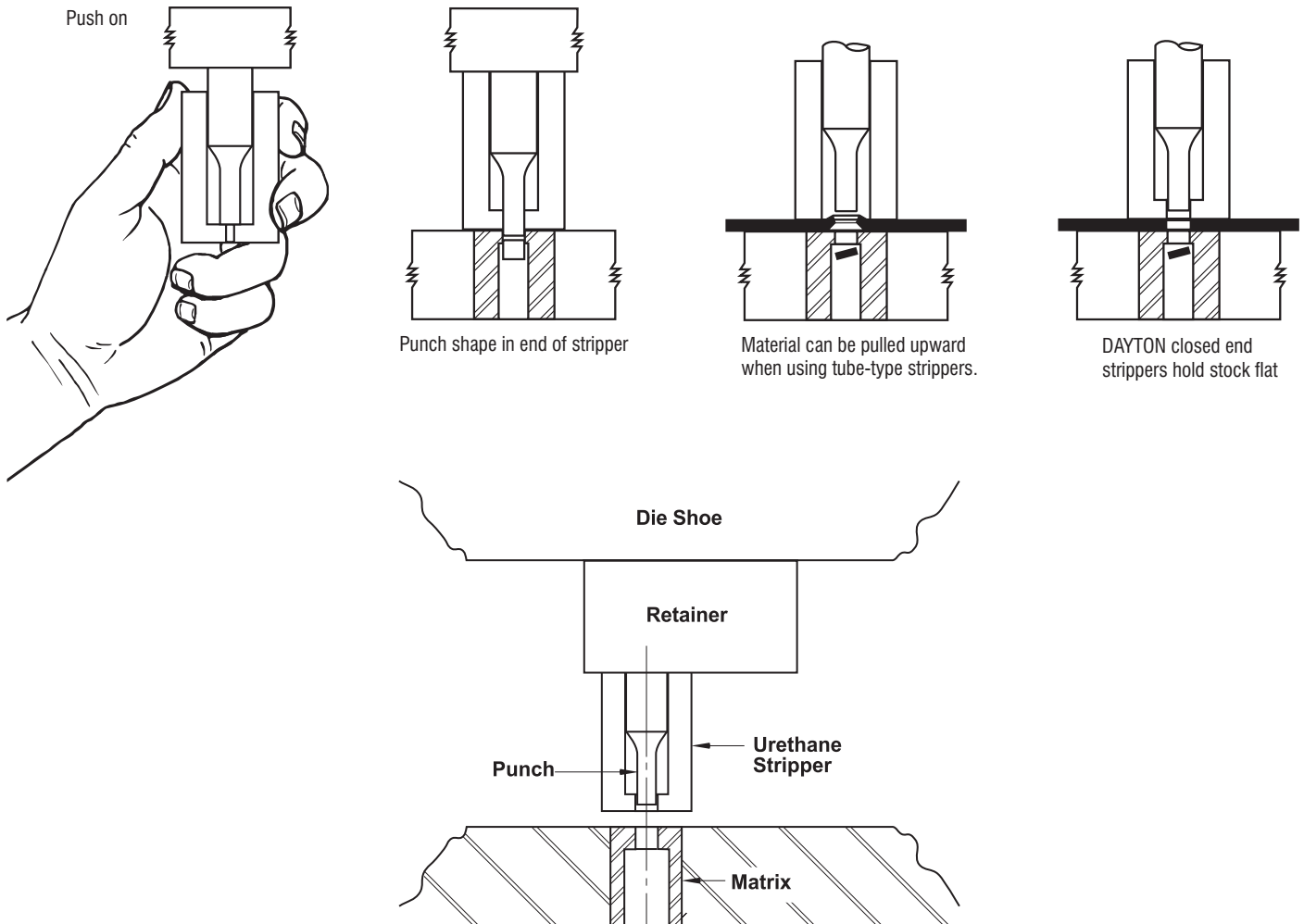
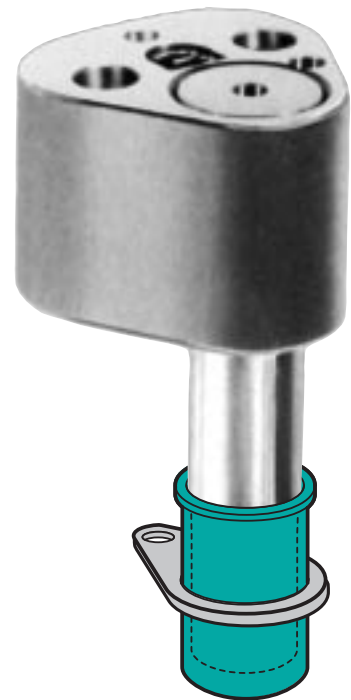

# ***SMART-Strip™*** ***Hard Face / Dual Durometer*** ***Urethane Strippers***

## **A New DAYTON PROGRESS Exclusive**

- Stamping shapes in thin material?
- Stamping pre-painted material?
- Short runs?
- Piercing on angles or complex contours?
- ...Any application where using a metal spring stripper is problematic or just not cost effective.

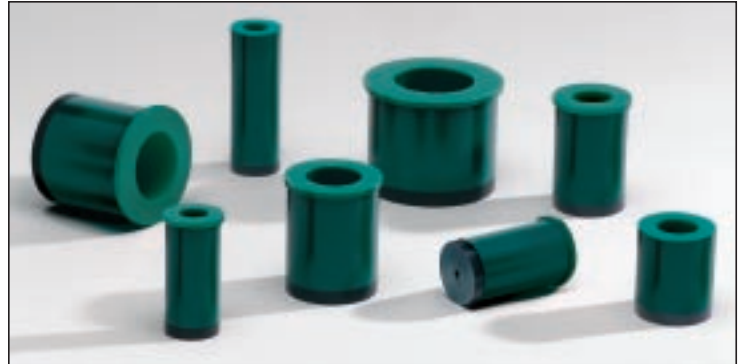

The answer is the new SMARTStrip™. Available only from DAYTON PROGRESS.

The body of the closed-end punch stripper is made of flexible, softer urethane elastomer 95A, enabling deflections up to 15%.

The 75D durometer hard face is elastic, durable and does not mark the surface of the sheet metal or prepainted material.

The SMARTStrip works similar to a metallic spring stripper plate that is machined to match the face of the punch tip.

Unlike strippers that have a piece of plastic or metal glued to the end, the hard face on the SMARTStrip can not separate from the body.

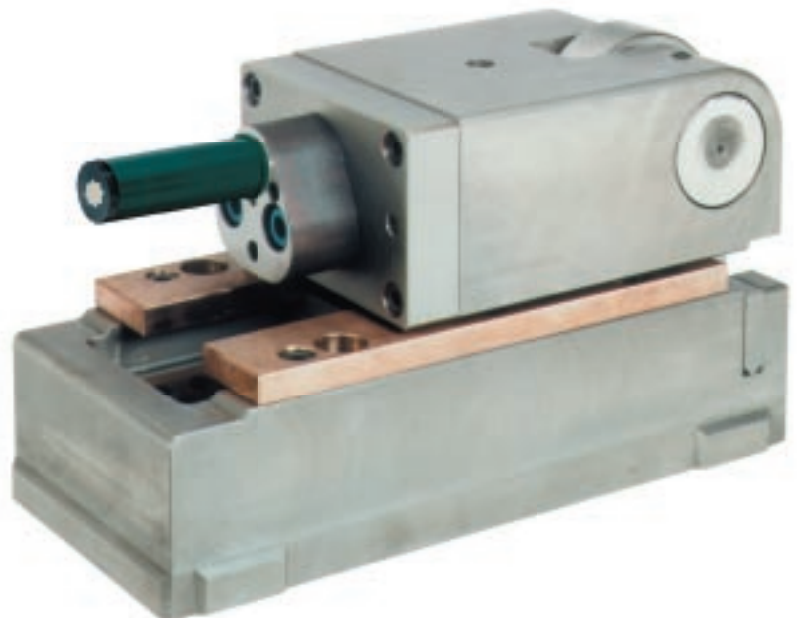
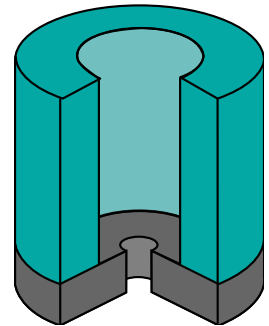

# Headed Strippers

- Designed to comply with NAAMS™ (North American Automotive Metric Standard) & FORD World Standard.
- The headed design prevents the strippers from falling into die.
- Fits most makes of standard retainers for head type and ball lock type punches. Standard durometer: 95A

D	d	d <sub>1</sub>	t	d <sub>2</sub>
10	18	21	6	1.6
13	23	26	6	3.0
16	28	31	6	3.0
20	33	36	7	3.0
25	40	43	7	3.0
32	50	55	7	3.0
38	60	65	8	3.0
40	60	65	8	3.0

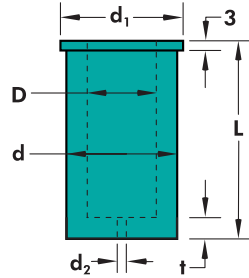

Urethane hardness: shore 95±2; maximum compression: 15% of overall length. (pressure ratings shown in Newtons)

NOTE: 43mm long bushings should not be compressed more than 6.5mm. More compression exceeds 15% recommended maximum.

UHM, UHS, UBP, and URP conform to NAAMS™ standards.

## UHS SMARTStrip™ Strippers

I.D.	O.D.	L	Catalog #	Pressure at Deflection of			Max Bulge
				3	6	9	
10	18	43	UHS-10-43	940	1395	—	22.7
		52	UHS-10-52	800	1285	1715	22.1
		63	UHS-10-63	685	965	1150	21.2
		72	UHS-10-72	580	855	1060	20.8
13	23	43	UHS-13-43	1425	2430	—	28.7
		52	UHS-13-52	1280	1870	2580	27.9
		63	UHS-13-63	970	1550	2010	27
		72	UHS-13-72	870	1470	1965	26.3
16	28	43	UHS-16-43	2320	3305	—	35.2
		52	UHS-16-52	2030	2960	3645	34.1
		63	UHS-16-63	1570	2360	3060	32.8
		72	UHS-16-72	1475	2245	2890	31.8
20	33	43	UHS-20-43	2930	4300	—	41.2
		52	UHS-20-52	2455	3445	4990	40.6
		63	UHS-20-63	2055	3140	4010	39.1
		72	UHS-20-72	1580	2205	2790	37.5
25	40	43	UHS-25-43	4040	6015	—	49.7
		52	UHS-25-52	3350	5470	6795	48.5
		63	UHS-25-63	2730	4185	5220	46.2
		72	UHS-25-72	2385	3630	4265	45.1
32	50	43	UHS-32-43	5960	8425	—	59.9
		52	UHS-32-52	5240	7875	9925	59.4
		63	UHS-32-63	4210	5855	8325	57.7
		72	UHS-32-72	3510	5340	6985	56
38	60	52	UHS-38-52	6645	9890	13785	69.5
		72	UHS-38-72	4935	7850	9425	67.5
40	60	43	UHS-40-43	7880	12115	—	69.5
		52	UHS-40-52	6470	9745	12680	68.9
63	UHS-40-63	6355	9045	11105	68.2		

t=6.3mm

# Headless Strippers

- Ideal for punching odd shaped holes.
- Assure positive stripping.
- Increases punch life, as punch stripper supports the punch tip, by dampening the vibration of the punch, as it pierces the sheet metal.

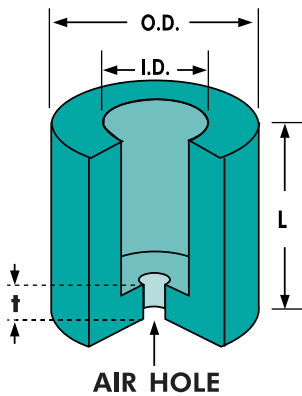

Urethane hardness: shore 95±2; maximum compression: 15% of overall length. (pressure ratings shown in Newtons)

## USS SMARTStrip™ Strippers

I.D.	O.D.	L	Catalog #	Pressure at Deflection of			Max Bulge
				1/8	1/4	3/8	
3/16	11/16	1 1/4	USS-18-125	300	490	—	3/16
		1 1/2	USS-18-150	230	350	—	1/8
1/4	3/4	1 1/4	USS-25-125	325	535	—	13/64
		1 1/2	USS-25-150	310	485	—	3/16
		1 3/4	USS-25-175	300	475	650	5/32
5/16	13/16	1 1/4	USS-31-125	335	565	—	7/32
		1 1/2	USS-31-150	295	475	—	3/16
		1 3/4	USS-31-175	290	465	645	5/32
		2	USS-31-200	285	455	600	9/64
3/8	7/8	1 1/4	USS-37-125	455	730	—	1/4
		1 1/2	USS-37-150	370	625	—	7/32
		1 3/4	USS-37-175	365	595	770	5/32
		2	USS-37-200	355	560	730	9/64
1/2	1	1 1/4	USS-50-125	540	825	—	5/16
		1 1/2	USS-50-150	520	800	—	1/4
		1 3/4	USS-50-175	465	735	900	7/32
		2	USS-50-200	440	715	875	3/16
5/8	1 1/8	2 1/4	USS-50-225	380	635	790	5/32
		1 1/4	USS-62-125	650	1000	—	11/32
		1 1/2	USS-62-150	560	870	—	9/32
		1 3/4	USS-62-175	515	820	1030	7/32
3/4	1 1/2	2	USS-62-200	500	810	1025	3/16
		1 3/4	USS-75-175	810	1275	1650	5/16
		2	USS-75-200	725	1140	1490	1/4
		2 1/4	USS-75-225	705	1090	1375	7/32
7/8	1 3/4	2 1/2	USS-75-250	545	950	1240	3/16
		2 3/4	USS-75-275	460	805	1030	5/32
		1 3/4	USS-87-175	1370	2040	2675	5/16
		2	USS-87-200	1155	1825	2395	9/32
1	2	2 1/4	USS-87-225	1050	1745	2310	1/4
		2 1/2	USS-87-250	990	1630	2220	7/32
		2 3/4	USS-87-275	835	1480	1830	3/16
		1 3/4	USS-100-175	1840	2825	3775	5/16
2	USS-100-200	1430	2305	2965	9/32		
2 1/4	USS-100-225	1115	1930	2525	5/32		
2 1/2	USS-100-250	1055	1840	2460	1/4		
2 3/4	USS-100-275	1030	1740	2330	7/32		

t=1/4"

# UHM



I.D.	O.D.	L	Catalog #	Pressure at Deflection of			Max Bulge
				3,0mm	6,0mm	9,0mm	
10	18	43	UHM-10-43	1015	1590	—	21.4
		52	UHM-10-52	930	1450	1760	21.2
		63	UHM-10-63	860	1305	1465	21
		72	UHM-10-72	765	1175	1215	20.7
13	23	43	UHM-13-43	1435	2645	—	28.5
		52	UHM-13-52	1215	2240	2815	27.6
		63	UHM-13-63	1030	2015	2530	26.6
		72	UHM-13-72	875	1835	2300	26
16	28	43	UHM-16-43	2335	3525	—	34
		52	UHM-16-52	2160	3310	4230	33
		63	UHM-16-63	1810	2905	4020	32
		72	UHM-16-72	1445	2510	3475	31.6
20	33	43	UHM-20-43	3075	4605	—	40.5
		52	UHM-20-52	2845	4240	5280	39.2
		63	UHM-20-63	2455	3750	4860	38.2
		72	UHM-20-72	2085	3250	4180	37
25	40	43	UHM-25-43	4140	6150	—	48.5
		52	UHM-25-52	3460	5505	7305	47.5
		63	UHM-25-63	2780	4860	6645	46
		72	UHM-25-72	2390	4530	5740	45
32	50	43	UHM-32-43	6490	8965	—	58.5
		52	UHM-32-52	5580	8320	10895	58
		63	UHM-32-63	4540	7675	9465	57
		72	UHM-32-72	3730	6980	8140	56
38	60	52	UHM-38-52	7360	11960	14265	69
		72	UHM-38-72	5805	10275	11970	66.5
40	60	43	UHM-40-43	8335	12450	—	70
		52	UHM-40-52	7410	10570	13635	69.5
		63	UHM-40-63	6380	9100	11970	68.5

t=6.3mm

# UBP

## Backing Plate

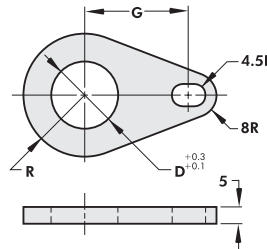

# URP

## Retaining Plate

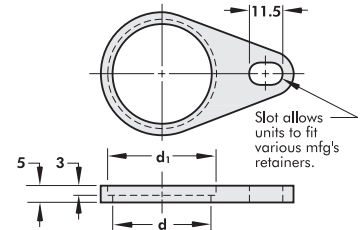

Catalog Plate #		D	d	d1	R	G	URP	EDP Set
Back	Retaining							
UBP10	URP10	10	19	22	13.0	28.0		748579
UBP13	URP13	13	24	27	15.5	31.0		748587
UBP16	URP16	16	29	32	18.0	32.9		748595
UBP20	URP20	20	34	37	20.5	34.8		748609
UBP25	URP25	25	41	44	24.0	39.8		748617
UBP32	URP32	32	51	56	31.0	41.3		748625
UBP38	URP38	38	61	66	36.0	45.0		748633
UBP40	URP40	40	61	66	36.0	45.0		748641

Set consists of: Backing Plate, Retaining Plate and M8 x 20 Socket Head Cap Screw.

# USE



I.D.	O.D.	L	Catalog #	Pressure at Deflection of			Max Bulge
				1/8	1/4	3/8	
3/16	11/16	1 1/4	USE-18-125	300	490	—	3/16
		1 1/2	USE-18-150	230	350	—	1/8
1/4	3/4	1 1/4	USE-25-125	325	535	—	13/64
		1 1/2	USE-25-150	310	485	—	3/16
		1 3/4	USE-25-175	300	475	650	5/32
5/16	13/16	1 1/4	USE-31-125	335	565	—	7/32
		1 1/2	USE-31-150	295	475	—	3/16
		1 3/4	USE-31-175	290	465	645	5/32
		2	USE-31-200	285	455	600	9/64
3/8	7/8	1 1/4	USE-37-125	455	730	—	1/4
		1 1/2	USE-37-150	370	625	—	7/32
		1 3/4	USE-37-175	365	595	770	5/32
		2	USE-37-200	355	560	730	9/64
1/2	1	1 1/4	USE-50-125	540	825	—	5/16
		1 1/2	USE-50-150	520	800	—	1/4
		1 3/4	USE-50-175	465	735	900	7/32
		2	USE-50-200	440	715	875	3/16
5/8	1 1/8	1 1/4	USE-50-225	380	635	790	5/32
		1 1/2	USE-62-125	650	1000	—	11/32
		1 1/2	USE-62-150	560	870	—	9/32
		1 3/4	USE-62-175	515	820	1030	7/32
3/4	1 1/2	2	USE-62-200	500	810	1025	3/16
		1 3/4	USE-75-175	810	1275	1650	5/16
		2	USE-75-200	725	1140	1490	1/4
		2 1/4	USE-75-225	705	1090	1375	7/32
7/8	1 3/4	2 1/2	USE-75-250	545	950	1240	3/16
		2 3/4	USE-75-275	460	805	1030	5/32
		1 3/4	USE-87-175	1370	2040	2675	5/16
		2	USE-87-200	1155	1825	2395	9/32
1	2	2 1/4	USE-87-225	1050	1745	2310	1/4
		2 1/2	USE-87-250	990	1630	2220	7/32
		2 3/4	USE-87-275	835	1480	1830	3/16
		1 3/4	USE-100-175	1840	2825	3775	5/16
1	2	2	USE-100-200	1430	2305	2965	9/32
		2 1/4	USE-100-225	1115	1930	2525	9/32
		2 1/2	USE-100-250	1055	1840	2460	1/4
		2 3/4	USE-100-275	1030	1740	2330	7/32

t=1/4"

# USM



I.D.	O.D.	L	Catalog #	Pressure at Deflection of			Max Bulge
				3	6.5	9.5	
06	19	45	USM-06-45	1190	1835	—	3.4
		53	USM-06-53	920	1490	2420	3.2
		71	USM-06-71	780	1250	1905	2.8
08	21	45	USM-08-45	1535	2340	—	3.4
		53	USM-08-53	1385	2180	2870	3.0
		71	USM-08-71	965	1510	2505	2.6
10	23	45	USM-10-45	1675	2555	—	4.0
		53	USM-10-53	1490	2360	2995	3.2
		56	USM-10-56	1430	2245	2880	2.8
		71	USM-10-71	1155	1990	2450	2.5
13	26	45	USM-13-45	1980	3075	—	4.5
		53	USM-13-53	1745	2760	3430	3.7
		56	USM-13-56	1590	2565	3110	3.3
		71	USM-13-71	1300	2120	2730	2.7
16	30	45	USM-16-45	2335	3680	—	5.5
		53	USM-16-53	2305	3620	4635	4.5
		56	USM-16-56	2300	3550	4510	3.8
		71	USM-16-71	1620	2760	3825	3.1
20	38	45	USM-20-45	4090	6395	—	6.7
		53	USM-20-53	3910	6360	8085	5.5
		71	USM-20-71	2845	4530	5820	3.8
25	50	45	USM-25-45	5840	9320	—	8.0
		53	USM-25-53	5480	9070	11520	6.7
		71	USM-25-71	4480	7640	9760	5.0

t=6.3mm

### How to Order:

Qty. Catalog No.

12 UHM-16-63

12 748595

6 USS-31-150

10 UHS-16-43

# Sheets, Rods & Bars

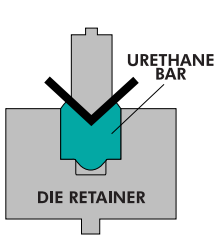

Square or rectangular shaped bars are used as bottom dies for scratch-free bending.

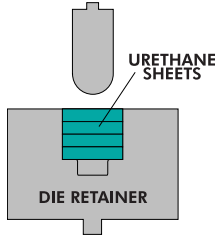

Sheets layered in a retainer offer multiple working surfaces and more penetration for radius bends.

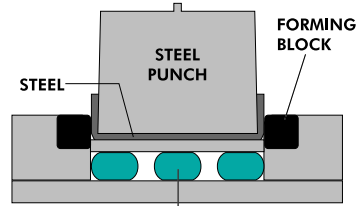

Used as pressure pads, they exert enormous amounts of pressures. When used as pressure pads, they can replace rows of springs or banks of nitrogen cylinders.

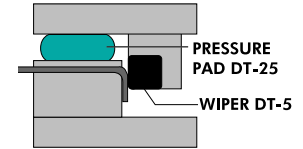

## UCS Cast Sheet Stock

W x L	Thickness														
	1/16"	1/8"	3/16"	1/4"	3/8"	1/2"	5/8"	3/4"	1"	1 1/4"	1 1/2"	2"	2 1/2"	3"	
1" x 48"	A1	B1	C1	D1	E1	F1	G1	H1	I1	J1	K1	L1	M1	N1	
2" x 48"	A2	B2	C2	D2	E2	F2	G2	H2	I2	J2	K2	L2	M2	N2	
3" x 48"	A3	B3	C3	D3	E3	F3	G3	H3	I3	J3	K3	L3	M3	N3	
4" x 48"	A4	B4	C4	D4	E4	F4	G4	H4	I4	J4	K4	L4	M4	N4	
6" x 6"	A5	B5	C5	D5	E5	F5	G5	H5	I5	J5	K5	L5	M5	N5	
6" x 12"	A6	B6	C6	D6	E6	F6	G6	H6	I6	J6	K6	L6	M6	N6	
6" x 24"	A8	B8	C8	D8	E8	F8	G8	H8	I8	J8	K8	L8	M8	N8	
6" x 48"	A10	B10	C10	D10	E10	F10	G10	H10	I10	J10	K10	L10	M10	N10	
12" x 12"	A11	B11	C11	D11	E11	F11	G11	H11	I11	J11	K11	L11	M11	N11	
12" x 24"	A13	B13	C13	D13	E13	F13	G13	H13	I13	J13	K13	L13	M13	N13	
12" x 36"	A14	B14	C14	D14	E14	F14	G14	H14	I14	J14	K14	L14	M14	N14	
12" x 48"	A15	B15	C15	D15	E15	F15	G15	H15	I15	J15	K15	L15	M15	N15	
18" x 24"	A17	B17	C17	D17	E17	F17	G17	H17	I17	J17	K17	L17	M17	N17	
18" x 36"	A18	B18	C18	D18	E18	F18	G18	H18	I18	J18	K18	L18	M18	N18	
18" x 48"	A19	B19	C19	D19	E19	F19	G19	H19	I19	J19	K19	L19	M19	N19	
24" x 24"	A20	B20	C20	D20	E20	F20	G20	H20	I20	J20	K20	L20	M20	N20	
24" x 36"	A21	B21	C21	D21	E21	F21	G21	H21	I21	J21	K21	L21	M21	N21	
24" x 48"	A22	B22	C22	D22	E22	F22	G22	H22	I22	J22	K22	L22	M22	N22	

### How to Order:

Qty.	Type	Code	Grade
12	UCS	A1	DT05
6	UBR	Y3	DT25
12	URD	S2	DT15

Grade	Deflection	Hardness	Color
DT05	5%	75D duro	Black
DT15	15%	95A duro	Amber
DT25	25%	90A duro	Red
DT35	35%	80A duro	Green
DT40	40%	60A duro	Yellow

## UBR Bars

Size W x H	Lengths				
	6"	12"	24"	36"	48"
1/2" x 1/2"	V1	W1	X1	---	---
3/4" x 3/4"	V2	W2	X2	---	---
1" x 1"	V3	W3	X3	Y3	Z3
1 1/4" x 1 1/4"	V4	W4	X4	Y4	Z4
1 1/2" x 1 1/2"	V5	W5	X5	Y5	Z5
2" x 2"	V6	W6	X6	Y6	Z6
3" x 2"	V7	W7	X7	Y7	Z7
3" x 3"	V8	W8	X8	Y8	Z8
4" x 4"	V9	W9	X9	Y9	Z9

## Pressure Ratings for Bars

Size W x H	Length	Pressure (lbs.) per 1/8" Deflection		
		DT-35 (80A)	DT-25 (90A)	DT-15 (95A)
1" x 1"	12"	4,000	6,700	9,800
	24"	8,100	13,750	19,950
	36"	12,500	21,000	30,200
	48"	16,400	27,800	40,600
2" x 2"	12"	3,700	6,400	9,300
	24"	7,800	13,350	19,350
	36"	12,000	21,400	29,700
	48"	16,200	27,600	40,000
2" x 3"	12"	7,700	12,700	18,500
	24"	17,200	28,000	41,500
	36"	27,200	43,900	65,800
	48"	36,500	60,000	90,000
3" x 2"	12"	2,000	3,500	5,400
	24"	4,200	7,000	11,000
	36"	6,300	10,600	16,600
	48"	8,400	14,300	22,100

## URD Rods

Dia.	Lengths				
	6"	12"	24"	36"	48"
1/4"	Q1	R1	S1	T1	U1
3/8"	Q2	R2	S2	T2	U2
1/2"	Q3	R3	S3	T3	U3
5/8"	Q4	R4	S4	T4	U4
3/4"	Q5	R5	S5	T5	U5
7/8"	Q6	R6	S6	T6	U6
1"	Q7	R7	S7	T7	U7
1 1/8"	Q8	R8	S8	T8	U8
1 1/4"	Q9	R9	S9	T9	U9
1 3/8"	Q10	R10	S10	T10	U10
1 1/2"	Q11	R11	S11	T11	U11
1 5/8"	Q12	R12	S12	T12	U12
1 3/4"	Q13	R13	S13	T13	U13
2"	Q14	R14	S14	T14	U14
2 1/4"	Q15	R15	S15	T15	U15
2 1/2"	Q16	R16	S16	T16	U16
3"	Q17	R17	S17	T17	U17
3 1/2"	Q18	R18	S18		
4"	Q19	R19	S19		
5"	Q20	R20	S20		
6"	Q21	R21	S21		

## Pressure Ratings for DT-25(90A) Solid Rods

Cylinder Size Diameter x Height	Load for Deflection by:		
	1/8"	1/4"	3/8"
1/2" x 1"	120	220	--
5/8" x 1 1/4"	170	295	460
3/4" x 1 1/2"	215	365	520
7/8" x 1 3/4"	250	430	610
1" x 2"	295	595	700
1 1/8" x 2 1/4"	360	590	810
1 1/4" x 2 1/2"	390	670	920
1 1/2" x 3"	520	820	1150
2" x 3"	920	1460	2000
3" x 3"	2060	3300	3650
4" x 3"	3700	5800	7100

