

WedgeLock™

WedgeLock retainers, available from Dayton Progress, are designed for applications where the quick interchangeability of ball lock is desired but conditions demand greater accuracy and rigidity.

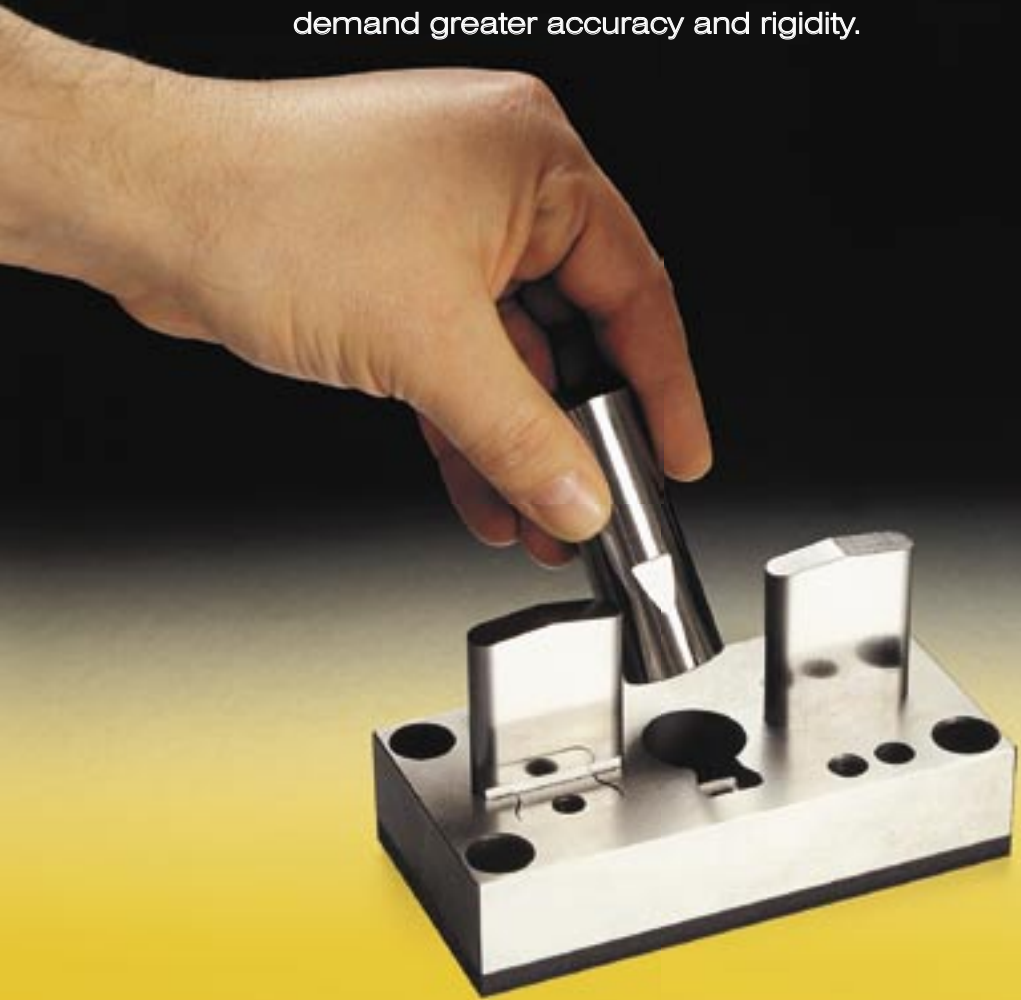

Global leader in quality metal fabrication and stamping tools

Subsidiary Federal Signal Corporation 



www.daytonprogress.com

WedgeLock™ Precision Retaining Systems

Product Applications

The *Dayton WedgeLock™ Precision Retaining System* utilizes a unique wedge-shaped locking mechanism to hold punches and matrixes in place more rigidly and accurately than conventional ball lock systems, yet allows tools to be changed without disassembling the die. Dayton's WedgeLock™ system has a wide range of applications in the metal stamping, forming, and fabricating industries.

Available system components include: *Multi-Position* and *Single Position Retainers* (bases); *Punches* (Jektole®, regular, blade, blanks, and pilots); and *Matrixes* (including blanks).

WedgeLock™ systems are available in a variety of configurations—standard or custom-designed—and include combination retainers that accommodate WedgeLock™, Ball Lock, and headed punches.

Ordering Information

When ordering a retainer base (single or multi-position), you are asked to specify the size and shape of the wedge and hole types and sizes. On multi-position retainers, you are asked to specify all dimensions from the datum on both the X and Y axes. Base alterations are also available on multi-position retainers. For additional information, see p. 4. Details for specifying wedge locations and determining space requirements are also shown in the drawings and charts on p. 4.

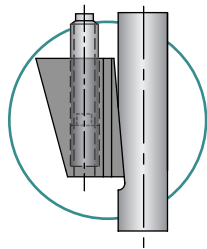

Punches and matrixes can be ordered as part of a single or multi-position WedgeLock™ system. Catalog pages contain specific instructions on how to order individual products. In addition, all punch and matrix pages include drawings and engineering charts

which show product shapes, dimensions, materials, and other information. You are asked to specify quantity, type, shank and length codes (for example), and other applicable data.

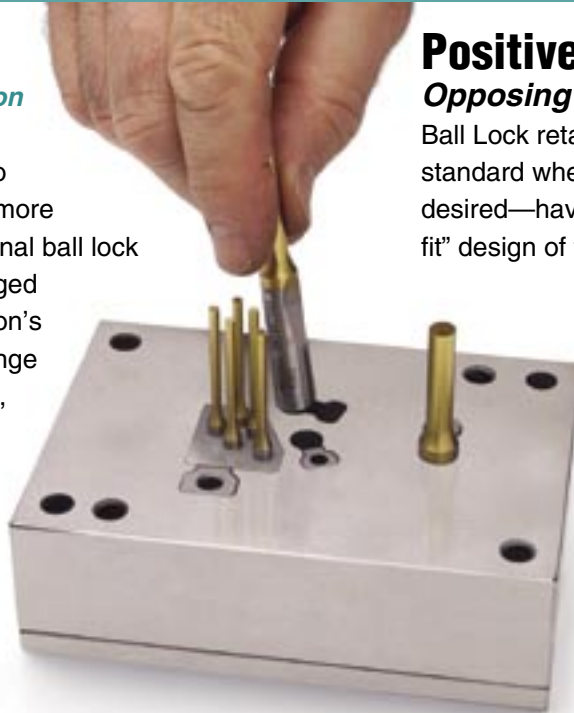

Positive Locking Mechanism Opposing Angled Planes

Ball Lock retainers—the accepted industry standard when quick interchangeability is desired—have some limitations due to the “slip-fit” design of the mechanism and the amount and type of contact with the retainer. The WedgeLock™ design provides maximum contact between the punch and the wedge, as shown in the drawing in the left-hand column and the enhanced cutaway at the bottom.

The opposing angled planes of the WedgeLock™ system offer more surface contact and create a positive “lock” against the wall of the retainer. This positive

lock minimizes lateral deflection, maintains the accuracy and rigidity of the punch, and allows punch replacement without disassembling the die.

Flexibility

The Dayton WedgeLock™ system can be incorporated into both single-hole or multi-hole retaining systems. In addition, the WedgeLock™ system can be used equally well in applications in which round punches or blade punches are used.



Because of its unique design flexibility, the WedgeLock™ system, offers manufacturers a precision hold on the punch, plus the ability to quickly change out the tool.

The WedgeLock™ Precision Retaining System is protected under US patents #6,182,545 and #6,669,399. Foreign patents applied for.

©2004 Dayton Progress Corporation. All Rights Reserved.

WedgeLock™ Retainers

WRP Multi-Position Retainers 4



WR_ Single Position Retainers 5

Round Shank / Blade Type

- WRT**
- WRX**
- WRO**
- WRR**
- WRK**



WedgeLock™ Punches

Standard Shapes



WJ_ Jektole® Punches 6

Round / Shape



WP_ Regular Punches 7

Round / Shape



WB_ Blade Punches 7

Round / Shape



WJB & WPB Punch Blanks 8

Jektole® /Regular



WedgeLock™ Pilots

WPT Pilots 9

Regular



WPA Pilots 9

Positive Pick-Up



Press Fit & WedgeLock™ Matrixes & Blanks

KD_ Headless Matrix 10

- WD_ Headless w/Seat Matrix**
- KH_ Headed Matrix**

Round / Shape



KD_ Headless Matrix Blank 10

- WD_ Headless w/Seat Matrix Blank**
- KH_ Headed Matrix Blank**



WedgeLock™ Alterations

Punches/Matrixes 11

Retainer alterations are available only on Multi-Position Retainers. For additional information, see p. 4.

All products with wedge seat are standard for 1.375 thick retainers. Other thicknesses must be specified at time of order.

WedgeLock™ Multi-Position Retainers

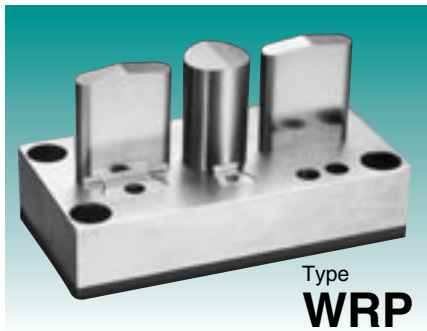

Type
WRP

Wedge Locations

Note: Radial location of wedge will determine alignment of shape for punch.

Location = $\pm 0^{\circ}1'$

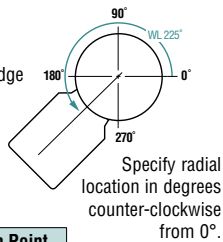

Specify radial location in degrees counter-clockwise from 0°.

Hole Reference	Re Datum Point
Dowel Holes	$\pm .0002$
Screw Holes	$\pm .005$
Component Holes	$\pm .0002$

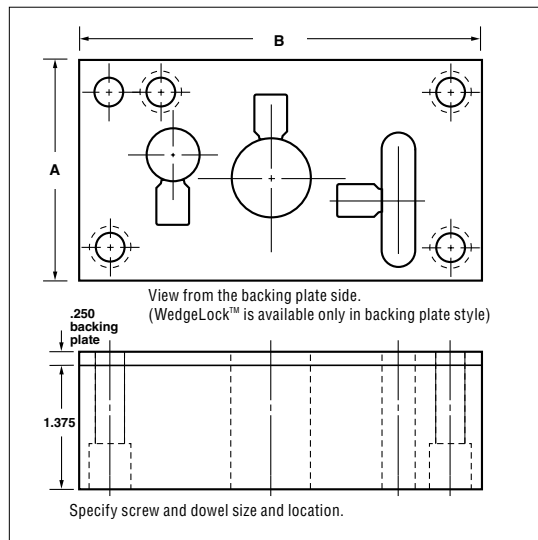

Space Requirements

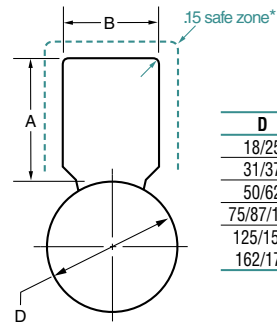

D	A	B
18/25	.735	.340
31/37	.715	.360
50/62	.755	.400
75/87/100	.815	.520
125/150/162/175	.875	.655

*** Note:** Extreme pressure is exerted on the wall and retainer, and the area immediately adjacent to the wedge is vulnerable to movement. To avoid fracture or an unsafe "lock," keep tooling outside the indicated "Safe Zone." Double the "Safe Zone" to outside edges of the retainer.

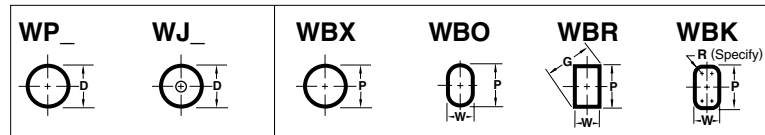

See page 6 & 7

See bottom of page 7

Special shapes per print

HOW TO ORDER

Specify: Qty. Code Ax B Special Size (optional)
Example: 2 WRP 3070 3.00 x 6.50

Multi-Position™ Retainers

Hole No.	Component		Location		Wedge Hole		P	W	R
	Type	Size	X Axis	Y Axis	Loc.	Style			
1	Dowel	5/16 S.F.*	.375	-.375					
2	S.H.C.S	5/16	1.000	-.375					
3	WPR	62	1.250	-1.000	270°	R	.4500	.3750	—
4	Clear	.25	1.500	-.3125					
5	WBX	100	3.000	-1.625	90°	X	1.005	—	—
6	WBO	125	5.000	-1.8125	180°	O	1.260	.3750	—
7	Jackscrew	Std.	5.625	-.500					

*Slip Fit

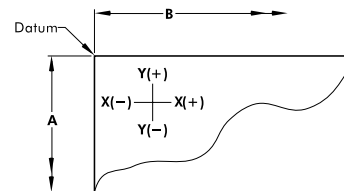

TYPE	A	B													
		2.50	2.75	3.00	3.25	3.50	3.75	4.00	5.00	6.00	7.00	8.00	9.00	10.00	12.00
WRP	2.00	2025	2027	2030	2032	2035	2037	2040	2050	2060	2070	2080	2090	2010	2012
	2.75		2727	2730	2732	2735	2737	2740	2750	2760	2770	2780	2790	2710	2712
	3.00		3027	3030	3032	3035	3037	3040	3050	3060	3070	3080	3090	3010	3012
	4.00							4040	4050	4060	4070	4080	4090	4010	4012
	6.00									6060	6070	6080	6090	6010	6012
	8.00											8080	8090	8010	8012

Standard Alterations

Standard Jackscrew Hole
Jackscrews make it easier to pull retainers from the dowels.

Special Size
Any amount of material can be removed from the sides of the retainer for a custom-size retainer. Edges are saw cut ± 0.3 .

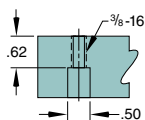

Clearance Holes

Clearance holes or tapped holes can be detailed as shown in the order form.

Holes are drilled through the retainer, unless otherwise specified.

Location ± 0.10

Diameter $+0.30$
 $+0.040$

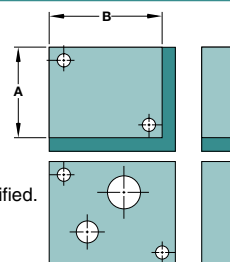

The following alterations require detailed drawings:

Notches

Notches to clear other tooling can be added to any side of the retainer. Notches are saw cut ± 0.3 .

Angles

As with notches, angles can be added to clear other tooling in the die. Angles are saw cut ± 0.3 .

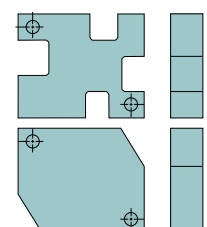

WedgeLock™ Single Position Retainers

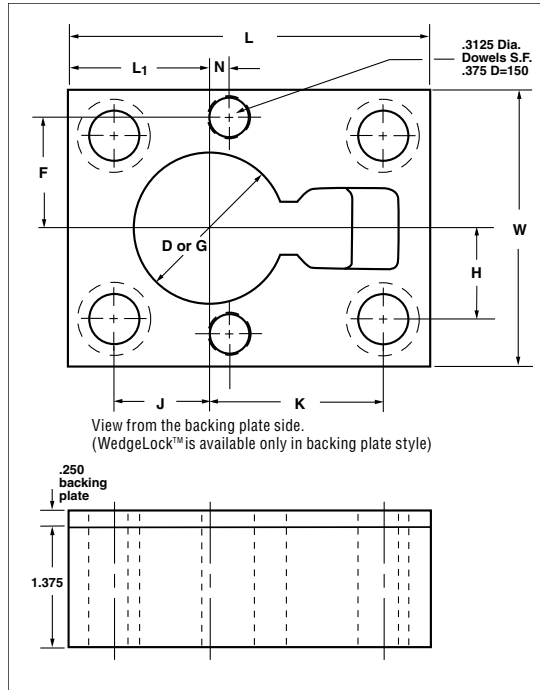

HOW TO ORDER

Specify:	Qty.	Type	D	Code	P (or P&W)
Example:	4	WRX	87		P.885
	3	WRR	62		P.500, W.345*
					* Note G=.6075

WedgeLock™ Single Position Retainer sets include:

- 1 Wedge
- 1 Backing Plate
- 4 Screws
- 2 Threaded Dowels
- 3 Backing Plate Screws

WRX



WRO



WRR



WRK

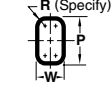

For Blade Punches WB_, see page 7

For Pointed Punches WJ_ & WP_, see pages 6-7

Hole Reference Re Punch Hole	
Dowel Holes	±.0002
Screw Holes	±.005

Round Cavity $+ .0008$, $+ .0005$, ≥ 1.25 $+ .0010$, $+ .0007$
 Shape Cavity $+ .0005$, $- .0000$

Round Shank Style Retainer for WJ_ and WP_ Punches

Product Code	D	L ₁	L	W	H	J	K	F	N	Mounting Screws (4)
WRT	.5000	.750	2.062	1.750	.562	.438	1.000	.6250	.1250	5/16 - 18
	.6250	.812	2.125	1.875	.625	.500	1.000	.6875	.1250	5/16 - 18
	.7500	.875	2.312	2.000	.688	.562	1.125	.7500	.2500	5/16 - 18
	.8750	1.000	2.500	2.250	.750	.625	1.125	.8750	.3125	3/8 - 16
	1.0000	1.062	2.625	2.375	.812	.688	1.188	.9375	.3125	3/8 - 16
	1.2500	1.250	3.000	2.500	.875	.875	1.375	1.0000	.3125	3/8 - 16
	1.5000	1.500	3.500	3.000	1.031	1.000	1.500	1.1875	.3750	1/2 - 13

Other sizes available on request.

Blade Punch Style Retainer

Product Code	Basic Cavity	Min. P	Max. Shape P/G	Min. Shape W*	L ₁	L	W	H	J	K	F	N	Mounting Screws (4)
WRX	50	.2500	.5100	.1250	.750	2.062	1.750	.562	.438	1.000	.6250	.1250	5/16 - 18
	62	.5101	.6350	.1250	.812	2.125	1.875	.625	.500	1.000	.6875	.1250	5/16 - 18
WRO	75	.6351	.7600	.1875	.875	2.312	2.000	.688	.562	1.125	.7500	.2500	5/16 - 18
WRR	87	.7601	.8850	.1875	1.000	2.500	2.250	.750	.625	1.125	.8750	.3125	3/8 - 16
	100	.8851	1.0100	.2500	1.062	2.625	2.375	.812	.688	1.188	.9375	.3125	3/8 - 16
WRK	125	1.0101	1.2600	.2500	1.250	3.000	2.500	.875	.875	1.375	1.0000	.3125	3/8 - 16
	150	1.2601	1.5100	.2500	1.500	3.500	3.000	1.031	1.000	1.500	1.1875	.3750	1/2 - 13

Other shapes and sizes available per print. * .250W recommended minimum to maintain maximum wedge strength.

WedgeLock™ Jektole® Punches



Type
WJ

Material / Tolerances

Steel: A2, M2, RC 60-63

Round P $\begin{matrix} +.0005 \\ -.0000 \end{matrix}$ $\begin{matrix} \text{P to D} \\ \text{P to D} \end{matrix}$

Shape P, W $\pm .0005$ $\begin{matrix} \text{P to D} \\ \text{P to D} \end{matrix}$

D = $\begin{matrix} +.0002 \\ +.0004 \end{matrix}$

D > 1.00 = $\begin{matrix} +.0002 \\ +.0006 \end{matrix}$

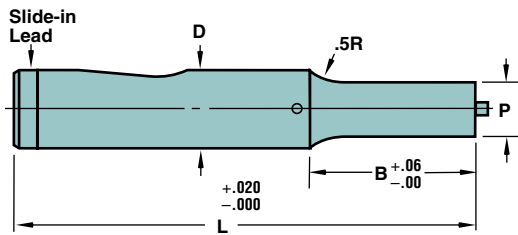

HOW TO ORDER

Specify: Qty. Type D Code L P (or P&W) Dimension Steel
Example: 6 WJX 37 C225 P.204 A2

Note: The standard location of a wedge is 0° or perpendicular to the P axis.

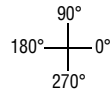

Standard Alterations

See p. 11 for additional ordering instructions.

WJX



WJO



WJR



WJL



WJH



WJJ



WJK



Shank	Point Length B*						Round		Shape			L																Jektole® Group						
	D	A	B	C	D	E	Min. XP	Range P	Min. XW	Min. W	Max. P/G	2.25	2.50	2.75	3.00	3.25	3.50	3.75	4.00	4.25	4.50	4.75	5.00	5.25	5.50	5.75	6.00		6.25	6.50	6.75	7.00		
.3750	.50	.75	1.00				.158	.187-.3749	.158	.187-.3750																								J6
.4375	.50	.75	1.00				.158	.187-.4374	.158	.187-.4375																							J6	
.5000	.50	.75	1.00				.158	.250-.4999	.158	.187-.5000																							J6	
.6250		.75	1.00	1.25			.235	.375-.6249	.235	.250-.6250																							J9	
.7500		.75	1.00	1.25			.300	.500-.7499	.235	.312-.7500																							J9	
.8750		.75	1.00	1.25	1.50		.350	.562-.8749	.235	.312-.8750																							J9	
1.0000		.75	1.00	1.25	1.50		.400	.625-.9999	.235	.312-1.0000																							J9	
1.2500				1.25	1.50		.450	.625-1.2499	.281	.312-1.2500																							J12	
1.5000				1.25	1.50		.450	.750-1.4999	.281	.312-1.5000																							J12	

* Point lengths must leave a minimum shank length of 1.50

See Standard Alterations on page 11 for minimum XP & XW limits.

Jektole® Components

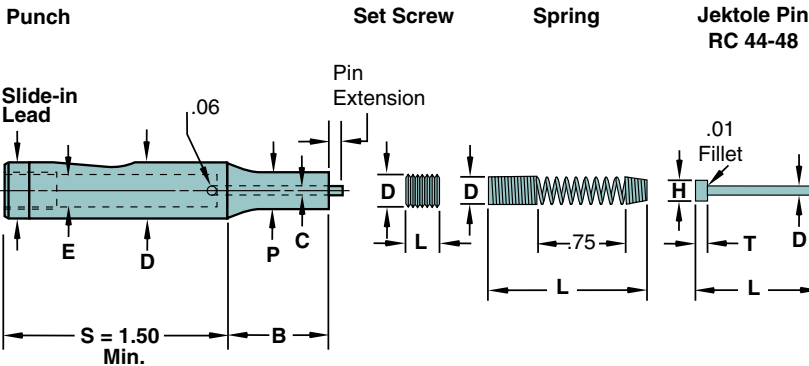

Standard Jektole® Data

DIMENSION		J6	J9	J12
Std. Shank Dia.	D	.3750	.6250	1.250 and larger
		.4375	.7500	
		.5000	1.0000	
Point Hole Dia.	C	.063	.094	.125
Shank Hole Dia.	E	.172	.221	.275
Pin Extension		.060	.060	.060
Keeper Key No.		920053		*

* Keeper Key not available

Jektole® Design Limits

DIMENSION		J6	J9	J12
Min. Shank Dia.	D	.344	.422	.552
Min. Point Dia.	P	.158	.235	.281
Max. Point Lgth.	B	1.620	1.620	1.620

Universal Jektole® Components

EJECTOR PINS		J6	J9	J12
Overall Length	L	1.940	2.220	2.220
Pin Diameter	D	.058	.089	.120
Head Diameter	H	.120	.156	.188
Head Thickness	T	.062	.094	.094
SPRINGS		J6	J9	J12
Outside Dia.	D	.167	.216	.270
Free Length	L	3.000	3.030	2.560
Pressure	Lbs.	1.500	2.000	2.500
SCREWS		J6	J9	J12
Screw Size	D	#10-32	1/4-28	5/16-24
Screw Length	L	.190	.250	.250

The Engineered Clearance

Perforating punch-to-matrix clearances in metal stamping dies have been universally expressed as a percentage of stock thickness, and for clarity should be articulated as percent per side (Δ =clearance per side).

Standard practice has called for Δ 5%, and is commonly known as "regular clearance." Regular clearance has been applied almost universally to all applications involving the perforation of ferrous materials.

Jektole®, the **Engineered Clearance**, is approximately twice regular clearance, i.e., Δ 10-12%. This means greater productivity, improved maintenance, and a better return on your tooling investment.

In addition, clearances of up to Δ 50% are not uncommon with some hard materials. Clearance tests have been performed by Dayton Progress to prove that increasing the clearance does not lessen hole quality—a common thought by some designers and engineers. Dayton clearance tests do, in fact, prove that the Jektole® **Engineered Clearance** provides many advantages and benefits.

WedgeLock™ Regular Punches

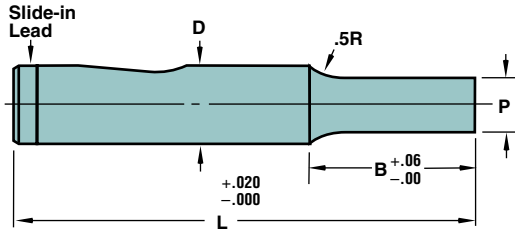

HOW TO ORDER

Specify: Qty. Type D Code L P (or P&W) Dimension Steel
 Example: 9 WPL 100 E350 P.872, W.401 A2

Note: The standard location of a wedge is 0° or perpendicular to the P axis.

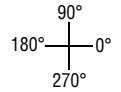

Standard Alterations

See p. 11 for additional ordering instructions.

Material / Tolerances

Steel: A2, M2, RC 60-63

Round P $\pm .0005$ Shape P, W $\pm .0005$

Round P $\pm .0005$ | P to D |
 Shape P, W $\pm .0005$ | P to D |

D = $\pm .0002$ / $\pm .0004$

D > 1.00 = $\pm .0002$ / $\pm .0006$

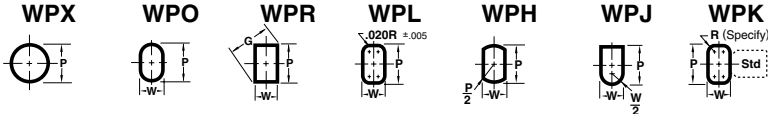

Shank D	Point Length B*					Round		Shape			L																						
	A	B	C	D	E	Min. XP	Range P	Min. XW	Min. W	Max. P/G	2.25	2.50	2.75	3.00	3.25	3.50	3.75	4.00	4.25	4.50	4.75	5.00	5.25	5.50	5.75	6.00	6.25	6.50	6.75	7.00			
.2500	.50	.75				.062	.062- .2499	.062	.093-	.2500																							
.3125	.50	.75	1.00			.062	.093- .3124	.062	.125-	.3125																							
.3750	.50	.75	1.00	1.25		.062	.125- .3749	.080	.187-	.3750																							
.4375	.75	1.00	1.25			.158	.187- .4374	.158	.187-	.4375																							
.5000	.75	1.00	1.25			.158	.250- .4999	.158	.187-	.5000																							
.6250	.75	1.00	1.25	1.50		.235	.375- .6249	.235	.250-	.6250																							
.7500	.75	1.00	1.25	1.50		.300	.500- .7499	.235	.312-	.7500																							
.8750	.75	1.00	1.25	1.50		.350	.562- .8749	.235	.312-	.8750																							
1.0000	.75	1.00	1.25	1.50		.400	.625- .9999	.235	.312-	1.0000																							
1.2500				1.25	1.50	.450	.625- 1.2499	.250	.312-	1.2500																							
1.5000				1.25	1.50	.450	.750- 1.4999	.250	.312-	1.5000																							

* Point lengths must leave a minimum shank length of 1.37.

See Standard Alterations on page 11 for minimum XP & XW limits.

WedgeLock™ Blade Punches

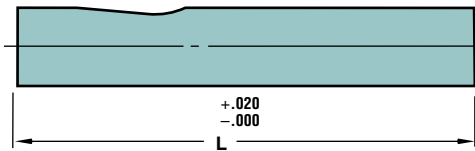

HOW TO ORDER

Specify: Qty. Type D Code L P (or P&W) Dimension Steel
 Example: 9 WBO 87 300 P.8760 W.2500 A2

Note: The standard location of a wedge is 0° or perpendicular to the P axis.

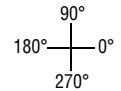

Standard Alterations

See p. 11 for additional ordering instructions.

Material

Steel: A2, M2, RC 60-63

Round P $\pm .0000$ Shape P, W $\pm .0000$

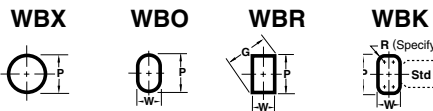

Special shapes per print

Round Shank Style

Product Code	Basic Body	Min. P	Max. P
WBX	50	.2500	.5100
	62	.5101	.6350
	75	.6351	.7600
	87	.7601	.8850
	100	.8851	1.0100
	125	1.0101	1.2600
	150	1.2601	1.5100

Other sizes available on request.

Blade Punch Style

Product Code	Basic Body	Min. W*	Min. P	Max. P/G
WB_	50	.1250	.2500	.5100
	62	.1250	.5101	.6350
	75	.1875	.6351	.7600
	87	.1875	.7601	.8850
	100	.2500	.8851	1.0100
	125	.2500	1.0101	1.2600
	150	.2500	1.2601	1.5100

*.2500 W recommended minimum

OAL

"L"
200
225
250
275
300
325
350
375
400

For economy and maximum strength, put shape on round shank product whenever possible. See WP_ and WJ_

WedgeLock™ Punch Blanks

Jektole®/Regular

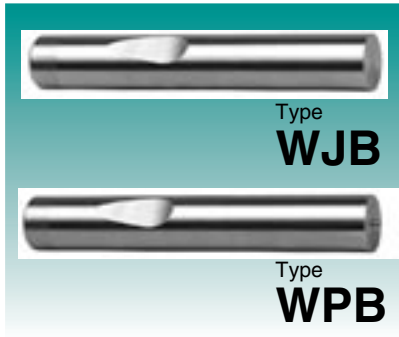

Type
WJB

Type
WPB

Material / Tolerances
 Steel: A2, M2, RC 60-63
 D= +.0002
 +.0004
 D>1.00= +.0002
 +.0006

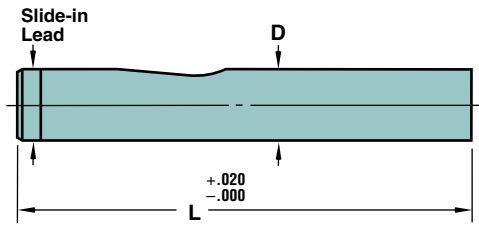
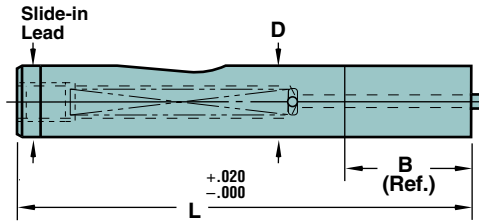

HOW TO ORDER

Specify:	Qty.	Type	D Code	L	Steel
Example:	9	WJB	37	B225	A2

Standard Alterations
 See p. 11 for additional ordering instructions.

Type	Shank		Point Length B					L															Jektole® Group				
	D	A	B	C	D	E	2.25	2.50	2.75	3.00	3.25	3.50	3.75	4.00	4.25	4.50	4.75	5.00	5.25	5.50	5.75	6.00		6.25	6.50	6.75	7.00
WJB	.3750	.50	.75	1.00			225	250	275	300	325	350	375	400	425	450	475	500	525	550	575	600	625	650	675	700	J6
	.4375	.50	.75	1.00																							J6
	.5000	.50	.75	1.00																							J6
	.6250		.75	1.00	1.25																						J9
	.7500		.75	1.00	1.25																						J9
	.8750		.75	1.00	1.25	1.50																					J9
	1.0000		.75	1.00	1.25	1.50																					J9
	1.2500				1.25	1.50																					J12
1.5000				1.25	1.50	J12																					
WPB	.2500						225	250	275	300	325	350	375	400	425	450	475	500	525	550	575	600	625	650	675	700	N/A
	.3125																										N/A
	.3750																										N/A
	.4375																										N/A
	.5000																										N/A
	.6250																										N/A
	.7500																										N/A
	.8750																										N/A
	1.0000																										N/A
	1.2500																										N/A
	1.5000																										N/A

WJB point lengths must leave a minimum shank length of 1.50

WedgeLock™ Regular Pilots



Material / Tolerances
 Steel: A2, M2, RC 60-63
 Round P $\begin{matrix} +.0005 \\ -.0000 \end{matrix}$ $\text{\textcircled{C}}$.0005 | P to D
 D = $\begin{matrix} +.0002 \\ +.0004 \end{matrix}$
 D > 1.00 = $\begin{matrix} +.0002 \\ +.0006 \end{matrix}$

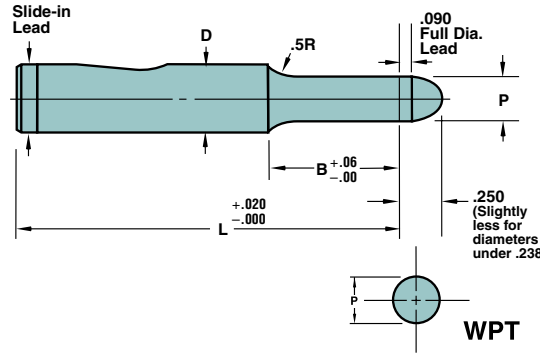

HOW TO ORDER
 Specify: Qty. Type D Code L P Dimension Steel
 Example: 2 WPT 50 C250 P.390 M2

Standard Alterations
 See p. 11 for additional ordering instructions.

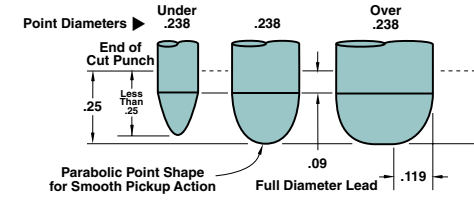

Shank D	Point Length B					Round		L																				
	A	B	C	D	E	Min. XP	Range P	2.25	2.50	2.75	3.00	3.25	3.50	3.75	4.00	4.25	4.50	4.75	5.00	5.25	5.50	5.75	6.00	6.25	6.50	6.75	7.00	
.2500	.50	.75				.061	.092-.2500																					
.3125	.50	.75	1.00			.061	.124-.3750	225																				
.3750	.50	.75	1.00	1.25		.061	.124-.3750																					
.4375	.75	1.00	1.25			.092	.186-.4375																					
.5000	.75	1.00	1.25			.124	.186-.5000																					
.6250	.75	1.00	1.25	1.50		.234	.374-.6250		250																			
.7500	.75	1.00	1.25	1.50		.299	.499-.7500			275	300	325	350	375	400	425	450	475	500	525	550	575	600					
.8750	.75	1.00	1.25	1.50		.349	.561-.8750																					
1.0000	.75	1.00	1.25	1.50		.399	.624-1.0000																					
1.2500			1.25	1.50		.449	.624-1.2500																					
1.5000			1.25	1.50		.449	.749-1.5000																					

Point lengths must leave a minimum shank length of 1.37

See Standard Alterations on page 11 for minimum XP limits.

WedgeLock™ Positive Pick-Up Pilots



Material / Tolerances
 Steel: A2, M2, RC 60-63
 Round P $\begin{matrix} +.0005 \\ -.0000 \end{matrix}$ $\text{\textcircled{C}}$.0005 | P to D
 D = $\begin{matrix} +.0002 \\ +.0004 \end{matrix}$
 D > 1.00 = $\begin{matrix} +.0002 \\ +.0006 \end{matrix}$

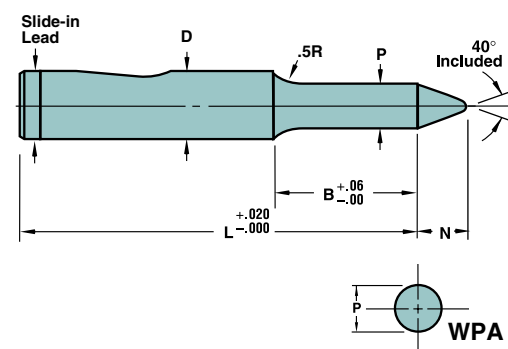

HOW TO ORDER
 Specify: Qty. Type D Code L P Dimension Steel
 Example: 4 WPA 100 525 P.875 M2

Standard Alterations
 See p. 11 for additional ordering instructions.

Shank D	Point Length B					Round		L																				
	B	C	D	E		Min. XP	Range P	N	2.50	2.75	3.00	3.25	3.50	3.75	4.00	4.25	4.50	4.75	5.00	5.25	5.50	5.75	6.00	6.25	6.50	6.75	7.00	
.2500	.75					.061	.061-.2500	.25																				
.3125	.75	1.00				.061	.092-.3125	.31																				
.3750	.75	1.00	1.25			.092	.186-.3750	.37																				
.4375	.75	1.00	1.25			.092	.186-.4375	.43																				
.5000	.75	1.00	1.25			.124	.249-.5000	.50																				
.6250	.75	1.00	1.25	1.50		.234	.311-.6250	.62																				
.7500	.75	1.00	1.25	1.50		.299	.436-.7500	.75		250																		
.8750	.75	1.00	1.25	1.50		.349	.561-.8750	.87			275	300	325	350	375	400	425	450	475	500	525	550	575	600				
1.0000	.75	1.00	1.25	1.50		.399	.624-1.0000	1.00																				
1.2500			1.25	1.50		.449	.624-1.2500	1.25																				
1.5000			1.25	1.50		.449	.750-1.5000	1.50																				

XL available at no charge within catalog range. (See Standard Alterations.)
 Point lengths must leave a minimum shank length of 1.37

Standard B length maintained.
 See Standard Alterations on page 11 for minimum XP limits.

Press Fit & WedgeLock™ Matrixes

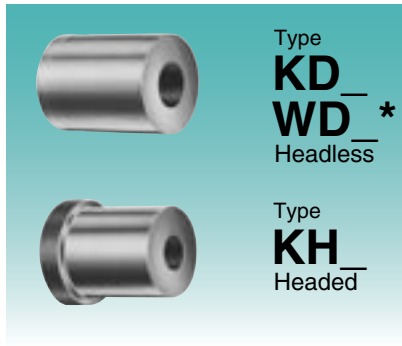

Type
KD
WD *
Headless

Type
KH
Headed

Material

Steel: A2, M2, RC 60-63.

Round P $\begin{matrix} +.0005 \\ -.0000 \end{matrix}$ $\begin{matrix} \text{P to D} \\ \text{P to D} \end{matrix}$
 Shape P, W $\begin{matrix} +.0001 \\ -.0000 \end{matrix}$ $\begin{matrix} \text{P to D} \\ \text{P to D} \end{matrix}$
 $D \geq 1.75$ $\begin{matrix} +.0002 \\ +.0006 \end{matrix}$

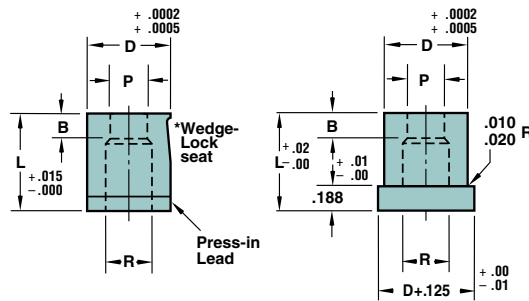

HOW TO ORDER

Specify: Qty. Type D L P (or P&W) Steel
 Example: 5 KDR 87 137 P.394, W.209 A2
 3 WDO 100 137 P.650, W.150 M2

Note: The standard location of a key flat or wedge seat is 0° or perpendicular to the P axis.

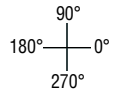

Standard Alterations

See p. 11 for additional ordering instructions.

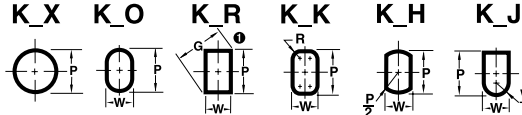

*Note: WedgeLock headless matrix available as a standard in 1.37 overall length. Change 'K' prefix to 'W' for product call-out. Matrix will be the same as Commercial product but with a wedge seat suitable for WRP or WRT retainers.

Type	Body D	Min. B	Max. R	Round		Shape		L								
				Range P	Min. W	Max. P/G	.750	.875	.937*	1.000	1.125	1.250	1.375**	1.500		
KD KH	.2500	.156	.156	.064-.135	.048-.135											
	.3125	.156	.191	.064-.171	.048-.171											
	.3750	.156	.228	.064-.195	.048-.195											
	.4375	.156	.281	.064-.250	.048-.250											
	.5000	.156	.312	.064-.285	.064-.285											
	.6250	.187	.391	.136-.365	.095-.365											
	.7500	.187	.468	.136-.435	.118-.435											
	.8750	.187	.578	.276-.545	.125-.545											
	1.0000	.250	.703	.356-.675	.125-.675		75	87	93	100	112	125	137	150		
	1.2500	.250	.828	.500-.800	.187-.800											
	1.5000	.250	1.094	.616-1.050	.187-1.050											
	1.7500	.312	1.430	.750-1.400	.187-1.400											
	2.0000	.312	1.630	.875-1.600	.187-1.600											
	2.2500	.312	1.830	1.000-1.800	.187-1.800											
	2.5000	.312	2.030	1.125-2.000	.187-2.000											
2.7500	.312	2.230	1.250-2.200	.187-2.200												

* Headless Only

** Standard WedgeLock overall length

Press Fit & WedgeLock™ EDM Matrix Blanks

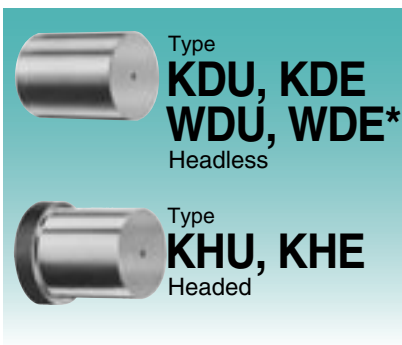

Type
KDU, KDE
WDU, WDE *
Headless

Type
KHU, KHE
Headed

Material

Steel: A2, M2, or RC 60-63

Round P $\pm .005$ $\begin{matrix} \text{P to D} \\ \text{P to D} \end{matrix}$
 $D \geq 1.75$ $\begin{matrix} +.0002 \\ +.0006 \end{matrix}$

HOW TO ORDER

Specify: Qty. Type D Code L P (or P&W) Steel
 Example: 6 KDE 37 100 XP.020 M2
 5 WDU 50 112 M2

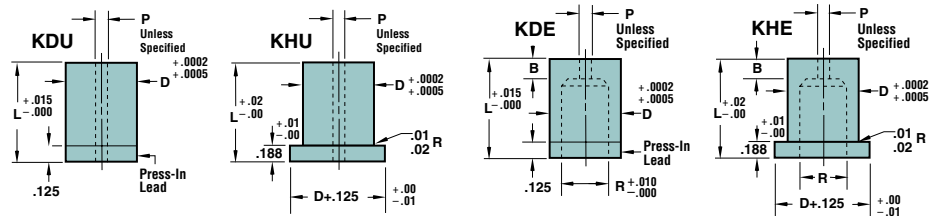

*Note: WedgeLock headless matrix available as a standard in 1.37 overall length. Change 'K' prefix to 'W' for product call-out. Matrix will be the same as Commercial product but with a wedge seat suitable for WRP or WRT retainers.

Type	Body D	K U			K E			L									
		Std. P	Optional P	—	Std. P	Optional P	—	B	R	.75	.87	.93*	1.00	1.12	1.25	1.37**	1.50
KD KH	.2500	.031	.020	—	.031	.020	—	.15	.156								
	.3125	.031	.020	—	.031	.020	—	.25	.191								
	.3750	.031	.020	—	.031	.020	—	.25	.228								
	.4375	.031	.020	—	.031	.020	—	.25	.281								
	.5000	.031	.020	—	.031	.020	—	.25	.312								
	.6250	.062	.020	.031	.093	.020	.031	.25	.391								
	.7500	.062	.020	.031	.093	.020	.031	.31	.468								
	.8750	.062	.020	.031	.093	.020	.031	.31	.578								
	1.0000	.062	.020	.031	.093	.020	.031	.31	.703	75	87	93	100	112	125	137	150
	1.2500	.062	.020	.031	.125	.020	.031	.37	.828								
	1.5000	.062	.020	.031	.125	.020	.031	.37	1.094								
	1.7500	.125	.020	.031	.125	.020	.031	.37	1.430								
	2.0000	.125	.020	.031	.125	.020	.031	.37	1.630								
	2.2500	.125	.020	.031	.125	.020	.031	.37	1.830								
	2.5000	.125	.020	.031	.125	.020	.031	.37	2.030								
2.7500	.125	.020	.031	.125	.020	.031	.37	2.230									

* Headless only

** Standard WedgeLock overall length

Standard Alterations—Punches & Matrixes

Standard Alterations

Punches and matrixes are available in sizes other than those listed in the front of the catalog.

Jektole®, Regular, Blade, & Punch Blanks

XP, XW P & W Dimensions
Smaller than Standard

XB Point Length
Longer than Standard

Point Length ▶	.500-.750	.751-1.000	1.001-1.250	1.251-1.500	1.501-1.625	.500-.750	.751-1.000	1.001-1.250	1.251-1.500	1.501-1.625	Jektole Group
Code	Type	Min. P (Rounds)				Min. W (Shapes)					
25	WP	.062	.062	.080	.093	.062	.062	.093	.125		
31	WP	.062	.062	.093	.093	.125	.062	.093	.093	.125	.195
37	WJ	.158	.158	.158	.158	.158	.158	.158	.172	.195	J6
	WP	.062	.062	.093	.125	.125	.080	.109	.125	.195	
43	WJ	.158	.158	.158	.158	.158	.158	.158	.172	.195	J6
	WP	.093	.093	.093	.125	.125	.109	.141	.172	.195	
50	WJ	.158	.158	.158	.158	.158	.158	.158	.172	.195	J6
	WP	.125	.125	.125	.125	.125	.125	.141	.172	.195	
62	WJ	.235	.235	.235	.235	.235	.235	.235	.235	.235	J9
	WP	.235	.235	.235	.235	.235	.235	.235	.235	.235	
75	WJ	.300	.300	.300	.300	.300	.235	.235	.235	.235	J9
	WP	.300	.300	.300	.300	.300	.235	.235	.235	.235	
87	WJ	.350	.350	.350	.350	.350	.235	.235	.235	.235	J9
	WP	.350	.350	.350	.350	.350	.235	.235	.235	.235	
100	WJ	.400	.400	.400	.400	.400	.235	.235	.235	.235	J9
	WP	.400	.400	.400	.400	.400	.235	.235	.235	.235	
125	WJ		.450	.450	.450	.450		.281	.281	.281	J12
	WP		.450	.450	.450	.450		.235	.235	.235	
150	WJ		.450	.450	.450	.450		.281	.281	.281	J12
	WP		.450	.450	.450	.450		.235	.235	.235	

XL Overall Length Shortened
Stock removal from point end which shortens B length.

LL Precision Overall Length
Same as XL except overall length is held to ±.001.

XN DayTride® A unique wear-resistant surface treatment for M2 only.

XK No Side Hole
For air ejection. No cost.

XNT DAYTiN® Titanium Nitride coating for extra wear for M2 only.

XJ Smaller Jektole Components

SBR Straight Before Radius

To determine Length of Radius Blend (LRB)

- Calculate (D-P)/2.
- Find (D-P)/2 value on left side of chart.
- Follow line over to intersection point on radius blend line.
- Read LRB value on bottom of chart.

Example:
D=.375 P=.175
(D-P)/2=(.375-.175)/2=.100
Following the .100 line on chart over the radius blend line shows the LRB to be approximately .300.

Regular & Positive Pick-Up Pilots

XP P Dimension Smaller than Standard

XB, XBB Point Length Longer than Standard

Alterations apply to both Positive Pick-Up & Regular Pilots.

Point Length ▶	.500-.750	.751-1.000	1.001-1.250	1.251-1.500	1.501-1.625
Code	Type	Min. P (Rounds)			
25	WPT	.061	.061	.079	.092
31	WPT	.061	.061	.092	.092
37	WPT	.061	.061	.092	.124
43	WPT	.092	.092	.092	.124
50	WPT	.124	.124	.124	.124
62	WPT	.234	.234	.234	.234
75	WPT	.299	.299	.299	.299
87	WPT	.349	.349	.349	
100	WPT	.399	.399	.399	
125	WPT	.449	.449	.449	
150	WPT	.449	.449	.449	

Point Length ▶	.500-.750	.751-1.000	1.001-1.250	1.251-1.500	1.501-1.625	1.626-2.000	2.001-2.500	2.501-3.000	
Code	Type	Min. P (Rounds)			XBB	X3B			
37	WPA	.092	.092	.092	.124	.157	.186	.249	.311
43	WPA	.092	.092	.092	.124	.124	.186	.249	.311
50	WPA	.124	.124	.124	.124	.124	.186	.249	.311
62	WPA	.234	.234	.234	.234	.234	.234	.311	.374
75	WPA	.299	.299	.299	.299	.299	.299	.342	.405
87	WPA	.349	.349	.349	.349	.349	.349	.374	.420
100	WPA	.399	.399	.399	.399	.399	.399	.399	.436
125	WPA	.449	.449	.449	.449	.449	.449	.449	.449
150	WPA	.449	.449	.449	.449	.449	.449	.449	.449

XL Overall Length Shortened
For WPT, stock removal from point end which shortens B length. For WPA, stock removal from point end, standard B length is maintained.

XN DayTride® A unique wear-resistant surface treatment for M2 only.

XNT DAYTiN® Titanium Nitride coating for extra wear for M2 only.

Matrixes

XP P Dimension Larger than Standard

Body D	25	31	37	43	50	62	75	87	100	125	150
Max. P/G	.171	.206	.250	.293	.344	.453	.562	.656	.750	.935	1.200

XL Overall Length Shortened
Stock removal does not alter land length on WD. Min. overall length: Headless = .25 Head type = .25+T

LL Precision Overall Length
Same as XL except overall length is held to ±.001

XN DayTride® A unique wear-resistant surface treatment for M2 only.

XNT DAYTiN® Titanium Nitride coating for extra wear available on M2 only.

DAYTON PROGRESS CORPORATION
500 Progress Road
P.O. Box 39
Dayton, Ohio 45449-0039 USA
Telephone: (937) 859-5111
Fax: (937) 859-5353

Dayton Progress Canada, Ltd.
861 Rowntree Dairy Road
Woodbridge, Ontario L4L 5W3
Telephone: (905) 264-2445
Fax: (905) 264-1071

Dayton Progress Ltd.
G1 Holly Farm Business Park
Honiley, Kenilworth
Warwickshire CV8 1NP UK
Telephone: 44 1 926 484192
Fax: 44 1 926 484172

Dayton Progress Corporation of Japan
2-7-35 Hashimotodai
Sagamihara-Shi, Kanagawa-Ken
229-1132 Japan
Telephone: 81 427 74 0821
Fax: 81 427 73 4955

Dayton Progress GmbH
Im Heidegraben 8
Postfach 1165
61401 Oberursel/Ts., Germany
Telephone: 49 61 71 924201
Fax: 49 61 71 924220

Dayton Progress SAS
105 Avenue de l'Épinette
BP 128
Zone Industrielle
77107 Meaux Cedex
France
Telephone: 33 1 60 247301
Fax: 33 1 60 247300



Global leader in quality metal fabrication and stamping tools