

PRESS ACCESSORIES



P/A INDUSTRIES INC.



Corporate Facilities



Manufacturing Plant



Assembly Plant

PRESS ACCESSORIES SELECTION CHART

Equipment	Page Number	Specifications	USA	Metric	
	PRECISION AIR FEED	6	Stock Width Feed Length Stock Thickness	1.5" – 12" 0-2" – 0-12" .040" – .090	38 mm – 230 mm 0-50 mm – 0-230 mm 1.0 mm – 2.3 mm
	HEAVY DUTY AIR FEED	12	Stock Width Feed Length Stock Thickness	12" 0-12" .128"	300 mm 0-300 mm 3.25 mm
	AIR FEED ACCESSORIES	14	Protective Cover Coil Set Eliminator Wire Feed Kit 3-Way On/Off Exhaust Valve Pilot Release Stock Clamp Filter/Regulator/Lubricator Repeater Control		
	BAND FEED	16	Stock Width Feed Length	3" – 9" 3" – 12"	76 mm – 230 mm 76 mm – 300 mm
	STOCK OILER	17	Stock Width Stock Thickness	4" – 24" .001 – .187"	100 mm – 600 mm 0.03 – 4.68 mm
	SCRAP CHOPPER	20	Stock Width Stock Thickness	3" – 12" .004 – .187"	76 mm – 305 mm .001 – 5.0 mm
	TRANSPORTER	24	Load Capacity	6 lbs. – 300 lbs.	3 Kg – 140 Kg

PRECISION AIR FEEDS

OVER FIFTY YEARS EXPERIENCE

Since 1954, P/A engineers have been designing and building equipment for the Metalforming Industry. Our commitment to provide innovative production equipment of the highest quality is second to none.

CUP SEAL DESIGN

P/A is the only Air Feed manufacturer that provides **low maintenance, high-cycle life cup wiper seals** on the main cylinder. This is the same technology that air cylinder manufacturers utilize. Cup seals reduce friction and heat which increases cycle life and performance by a conservative factor of 50 times.

FASTER SPEEDS

Our patented system sequences high speed models up to 400 cycles per minute for faster and more accurate feeding.

VERSATILE

Coil stock can be fed in any direction or angle at any time during the machine cycle. A single feed can push or pull through long or short progressions. A variety of stock widths and thicknesses can be fed at different speeds and feed lengths. Two or more strips can be simultaneously fed by the same feed.

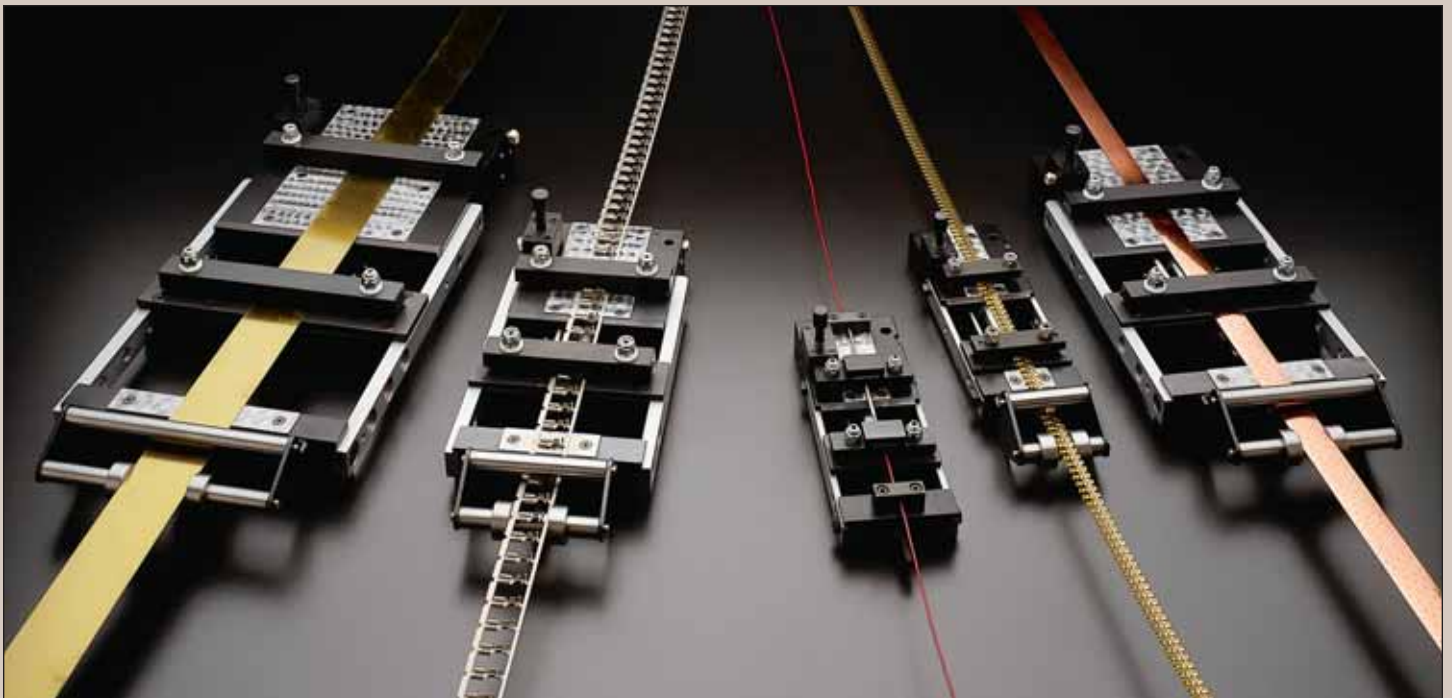

INEXPENSIVE

The cost of P/A feeds are 65% to 90% less than conventional roll or slide feeds. With savings like that, consider leaving the feed permanently mounted on the tool to decrease set up time and increase productivity.

HANDLES VARIETY OF MATERIALS

Paper, plastic, foil, fabric, wire, tubing . . . You name it and P/A will feed it. Highly polished materials or extrusions, preformed or irregularly shaped materials – all can easily be adapted with special clamps.

SIMPLE INSTALLATION

Our feeds are extremely easy to mount. Two (or four) mounting bolts and a single air line connection are all that's necessary. Compact, clean design permits the P/A Air Feed to be mounted right on the die set.

QUICK SET-UP

Adjustments are quick, simple, and positive. To change feed length, turn the adjustment screw to the desired pitch between positive stops and tighten locknut. Surveys show that Contract Job Shop Stampers prefer P/A Air Feeds because they are the easiest and most economical way to change from one job to another.

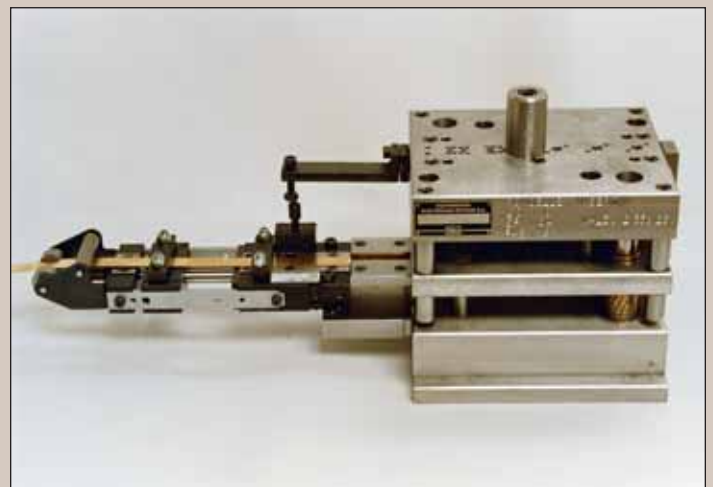
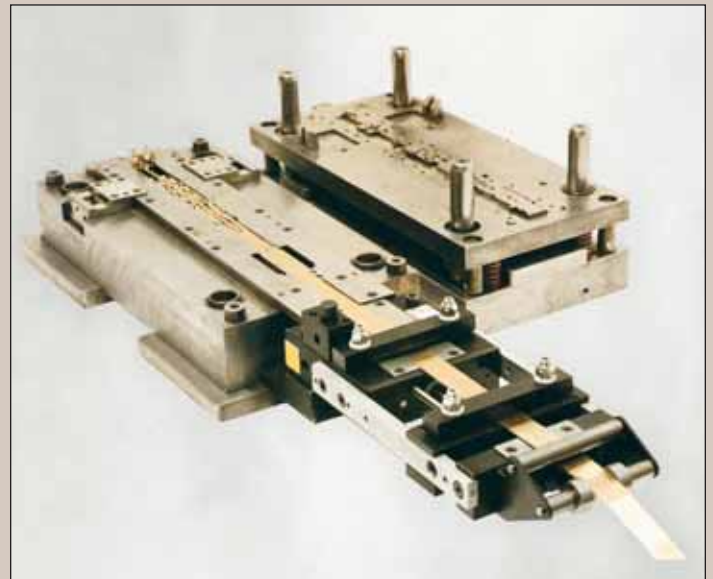
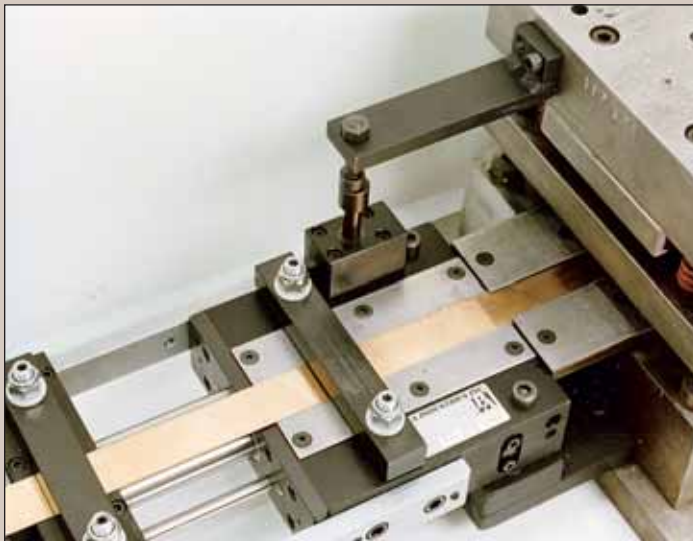

PRECISION AIR FEED

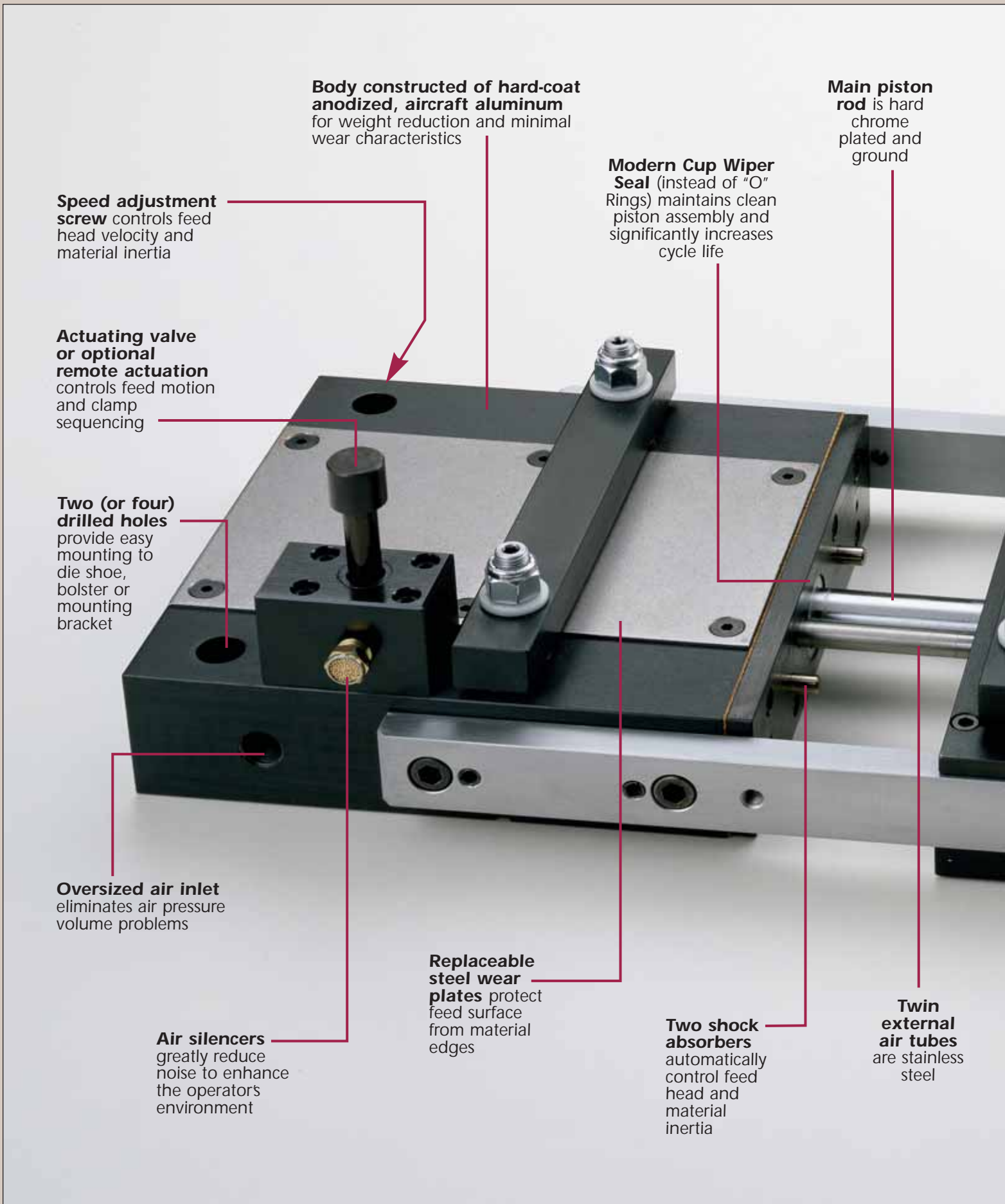

Body constructed of hard-coat anodized, aircraft aluminum for weight reduction and minimal wear characteristics

Main piston rod is hard chrome plated and ground

Modern Cup Wiper Seal (instead of "O" Rings) maintains clean piston assembly and significantly increases cycle life

Speed adjustment screw controls feed head velocity and material inertia

Actuating valve or optional remote actuation controls feed motion and clamp sequencing

Two (or four) drilled holes provide easy mounting to die shoe, bolster or mounting bracket

Oversized air inlet eliminates air pressure volume problems

Replaceable steel wear plates protect feed surface from material edges

Two shock absorbers automatically control feed head and material inertia

Twin external air tubes are stainless steel

Air silencers greatly reduce noise to enhance the operator's environment

Nylock hex nut
used in aircraft
engines to absorb
vibration and
eliminate loosening

**Large adjusting
bolt and lock
nut** provide
*vernier feed
length* control

**Shock
absorber**
stops
slamming
and reduces
noise

**Combination
stock
dampener
and adjustable
guide rollers**
provide vibration
free material to
the feed



TWO YEAR WARRANTY

At P/A, our goal is to provide the best production Air Feed available anywhere in the world. To back this up, we provide a Two Year Warranty on our Air Feeds – the only one in the industry.

FREE REPAIR & SERVICE CERTIFICATE

In addition, we enclose a Free Repair & Service Certificate with every Feed we ship. This Certificate can be used at any time.

Covered by one or more of the following U.S. Patent Numbers:

- 3,329,327; 3,462,056; 3,485,430;
- 3,561,657; 3,583,268; 3,561,309;
- 3,847,320; 4,051,987; 4,195,161;
- 4,310,114; 4,160,518; 4,076,161;
- 4,095,733; 4,140,261; 4,175,688;
- 4,290,541; 4,261,238; 4,277,997;
- 4,207,999; 4,267,950; 4,329,897;
- 4,351,462; 4,399,937; 4,444,346;
- 4,531,662; 4,619,390.



**High strength,
chrome plated,
steel guide rails**
maintain feed head
alignment throughout
its stroke

**Counterbored holes
and precision ground
shoulder screws** provide *coarse feed length* adjustment and secure rigid alignment

AIR FEED SPECIFICATIONS

USA

Model	Max. Stock Width (In.)	Feed Length (In.)	Pulling Power at 100 PSI (Lbs.)	Thickness (In.)	Speed See Note 3 (SPM)	Air Consumption Per Cycle (CF)	Shipping Weight (Lbs.)
AX2	1.5	0-2	25	.050	280	.001	7.5
AX4	1.5	0-4	25	.045	220	.002	9
AX6	1.5	0-6	25	.040	180	.003	11
CX3	3	0-3	50	.080	220	.003	20
CX6	3	0-6	50	.075	160	.005	25
CX9	3	0-9	50	.070	110	.008	29
CX12	3	0-12	50	.065	95	.010	32
DX4	4	0-4	50	.075	195	.004	25
DX6	4	0-6	50	.070	145	.006	30
DX12	4	0-12	50	.065	85	.012	38
FX4	6	0-4	110	.085	160	.006	38
FX6	6	0-6	110	.080	140	.008	40
FX9	6	0-9	110	.075	110	.011	45
FX12	6	0-12	110	.070	80	.014	51
HX4	9	0-4	110	.075	145	.006	55
HX6	9	0-6	110	.070	125	.008	60
HX9	9	0-9	110	.065	100	.011	65
HX12	9	0-12	110	.065	70	.014	70
LX6	12	0-6	175	.090	100	.013	130
LX12	12	0-12	175	.080	60	.023	155

METRIC

Model	Max. Stock Width (mm)	Feed Length (mm)	Pulling Power at 7 Bar (Kg)	Thickness (mm)	Speed See Note 3 (SPM)	Air Consumption Per Cycle (LTR)	Shipping Weight (Kg)
AX2	38	0-50	11,4	1,2	280	0,03	3,5
AX4	38	0-100	11,4	1,1	220	0,06	4,0
AX6	38	0-150	11,4	1,0	180	0,09	5,0
CX3	76	0-76	23	2,0	220	0,09	9,0
CX6	76	0-150	23	1,9	160	0,14	11,0
CX9	76	0-230	23	1,8	110	0,23	13,0
CX12	76	0-300	23	1,7	95	0,28	14,5
DX4	100	0-100	23	1,9	195	0,11	11,0
DX6	100	0-150	23	1,8	145	0,17	13,5
DX12	100	0-300	23	1,6	85	0,34	17,0
FX4	150	0-100	50	2,1	160	0,17	18,0
FX6	150	0-150	50	2,0	140	0,23	19,0
FX9	150	0-230	50	1,9	110	0,31	20,0
FX12	150	0-300	50	1,8	80	0,40	23,0
HX4	230	0-100	50	2,0	145	0,17	25,0
HX6	230	0-150	50	1,9	125	0,23	27,0
HX9	230	0-230	50	1,8	100	0,31	29,5
HX12	230	0-300	50	1,7	70	0,40	31,8
LX6	300	0-150	80	2,3	100	0,37	59,0
LX12	300	0-300	80	2,0	60	0,65	70,0

Note 1: Recommended Operating Pressure 80 to 120 PSI (6 to 8 Bar).

Note 2: Capacity for stock thickness increases as stock width decreases to a maximum of 150%.

Note 3: Approximate speed at maximum feed length. Speed will decrease as the weight of the material being fed increases.

SAFE WORKING SPEEDS AT VARYING LENGTHS

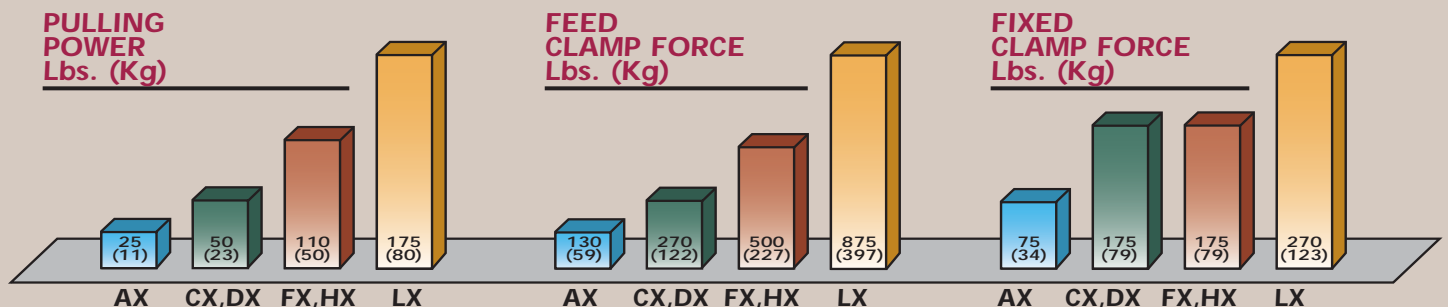
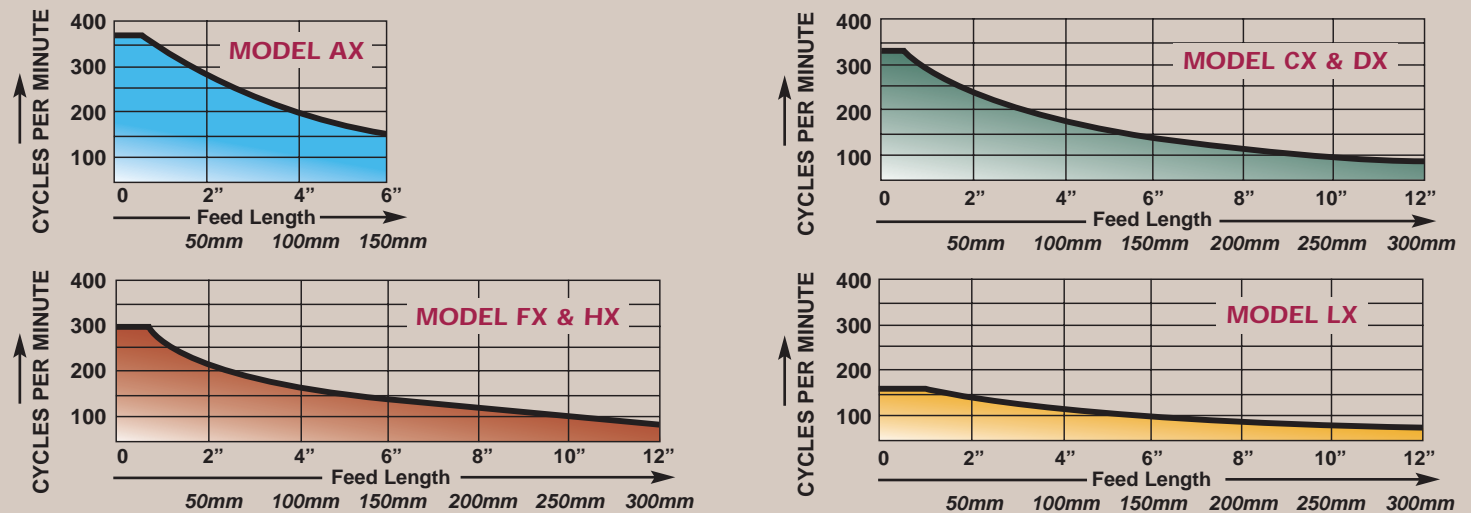

Note: All Calculations at 100 PSI (7 Bar)

AIR FEED DIMENSIONS

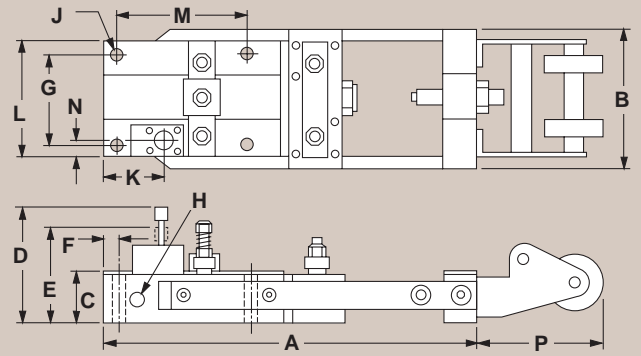
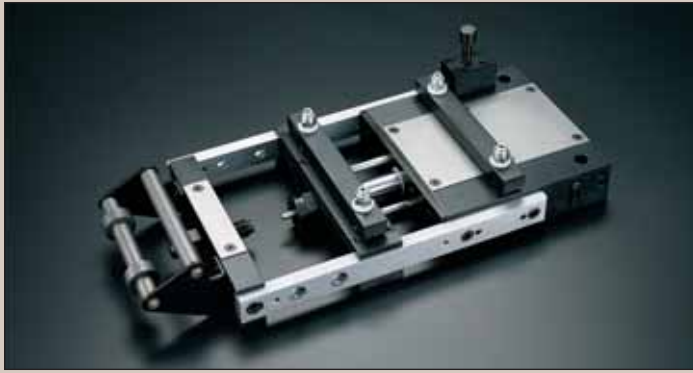

DIMENSIONS - inches

Model	A	B	C	D	E	F	G	H	J	K	L	M	N	P
AX2	9.38	3.62	1.29	3.55	2.84	.83	2.62	1/8 NPT	.33	2.17	3.46	-	.50	3
AX4	13.38	3.62	1.29	3.55	2.84	.83	2.62	1/8 NPT	.33	2.17	3.46	-	.50	3
AX6	17.38	3.62	1.29	3.55	2.84	.83	2.62	1/8 NPT	.33	2.17	3.46	-	.50	3
CX3	12.25	6.50	1.79	4.61	3.64	.83	4.5	1/4 NPT	.39	2.33	5.50	-	.56	3
CX6	18.25	6.50	1.79	4.61	3.64	.83	4.5	1/4 NPT	.39	2.33	5.50	-	.56	3
CX9	24.25	6.50	1.79	4.61	3.64	.83	4.5	1/4 NPT	.39	2.33	5.50	-	.56	3
CX12	30.25	6.50	1.79	4.61	3.64	.83	4.5	1/4 NPT	.39	2.33	5.50	-	.56	3
DX4	14.61	7.75	1.79	4.61	3.64	.90	5.5	1/4 NPT	.53	2.65	6.75	-	.56	3
DX6	18.61	7.75	1.79	4.61	3.64	.90	5.5	1/4 NPT	.53	2.65	6.75	-	.56	3
DX12	30.61	7.75	1.79	4.61	3.64	.90	5.5	1/4 NPT	.53	2.65	6.75	-	.56	3
FX4	17.25	9.75	2.04	4.89	3.92	.97	7.5	3/8 NPT	.66	2.80	8.75	6	.56	3
FX6	19.25	9.75	2.04	4.89	3.92	.97	7.5	3/8 NPT	.66	2.80	8.75	6	.56	3
FX9	25.25	9.75	2.04	4.89	3.92	.97	7.5	3/8 NPT	.66	2.80	8.75	6	.56	3
FX12	31.25	9.75	2.04	4.89	3.92	.97	7.5	3/8 NPT	.66	2.80	8.75	6	.56	3
HX4	17.25	12.75	2.04	4.89	3.92	.97	10.5	3/8 NPT	.66	2.80	11.75	6	.56	3
HX6	19.25	12.75	2.04	4.89	3.92	.97	10.5	3/8 NPT	.66	2.80	11.75	6	.56	3
HX9	25.25	12.75	2.04	4.89	3.92	.97	10.5	3/8 NPT	.66	2.80	11.75	6	.56	3
HX12	31.25	12.75	2.04	4.89	3.92	.97	10.5	3/8 NPT	.66	2.80	11.75	6	.56	3
LX6	21.12	16.75	2.30	5.15	4.18	1.00	14.0	1/2 NPT	.66	3.00	15.75	6	.56	3.62
LX12	33.12	16.75	2.30	5.15	4.18	1.00	14.0	1/2 NPT	.66	3.00	15.75	6	.56	3.62

DIMENSIONS - mm

Model	A	B	C	D	E	F	G	H	J	K	L	M	N	P
AX2	238	92	33	90	72	21	66,5	1/8 NPT	8,4	55	88	-	13	80
AX4	339	92	33	90	72	21	66,5	1/8 NPT	8,4	55	88	-	13	80
AX6	441	92	33	90	72	21	66,5	1/8 NPT	8,4	55	88	-	13	80
CX3	311	165	45,5	117	92	21	114	1/4 NPT	10	59	140	-	14	80
CX6	464	165	45,5	117	92	21	114	1/4 NPT	10	59	140	-	14	80
CX9	616	165	45,5	117	92	21	114	1/4 NPT	10	59	140	-	14	80
CX12	769	165	45,5	117	92	21	114	1/4 NPT	10	59	140	-	14	80
DX4	371	197	45,5	117	92	23	140	1/4 NPT	13,5	67	172	-	14	80
DX6	473	197	45,5	117	92	23	140	1/4 NPT	13,5	67	172	-	14	80
DX12	777	197	45,5	117	92	23	140	1/4 NPT	13,5	67	172	-	14	80
FX4	438	248	52	124	100	24,6	190,5	3/8 NPT	16,7	71	223	152,4	14	80
FX6	489	248	52	124	100	24,6	190,5	3/8 NPT	16,7	71	223	152,4	14	80
FX9	641	248	52	124	100	24,6	190,5	3/8 NPT	16,7	71	223	152,4	14	80
FX12	794	248	52	124	100	24,6	190,5	3/8 NPT	16,7	71	223	152,4	14	80
HX4	438	329	52	124	100	24,6	267	3/8 NPT	16,7	71	299	152,4	14	80
HX6	489	329	52	124	100	24,6	267	3/8 NPT	16,7	71	299	152,4	14	80
HX9	641	329	52	124	100	24,6	267	3/8 NPT	16,7	71	299	152,4	14	80
HX12	794	329	52	124	100	24,6	267	3/8 NPT	16,7	71	299	152,4	14	80
LX6	536	425	58,4	131	106	25,4	355,6	1/2 NPT	16,7	76	400	152,4	14	92
LX12	841	425	58,4	131	106	25,4	355,6	1/2 NPT	16,7	76	400	152,4	14	92

PRESS FEED TIMING & SEQUENCE

The Reciprocating Linear Motion of the Feed Slide must be timed to the press crankshaft rotation for optimum performance. The Actuating Valve's vertical motion initiates the sequencing of the Stock Clamp, Feed Clamp, and the Feed Slide.

To understand how the rotary crankshaft and linear Feed Slide motion work together in a Press Feed Cycle, it might be helpful to visualize a Clock Face. The position "Top Dead Center" of the Ram Stroke would be 12 o'clock, half way down would be 3 o'clock, "Bottom Dead Center" is 6 o'clock, and moving half way up would be 9 o'clock.

The optimum Feed cycle requires two thirds of the crankshaft rotation (240 degrees) to feed the material into position. During the remaining 120 degrees, the Feed Slide returns to the Stop Screw for more Material. As soon as the Stamped Part has been **ejected** and the Punches are clear of the Die (approximately 8 to 8:30 on the clock), the Feed Clamp will grip the Stock and then the Feed Slide will begin moving towards the Feed Body.

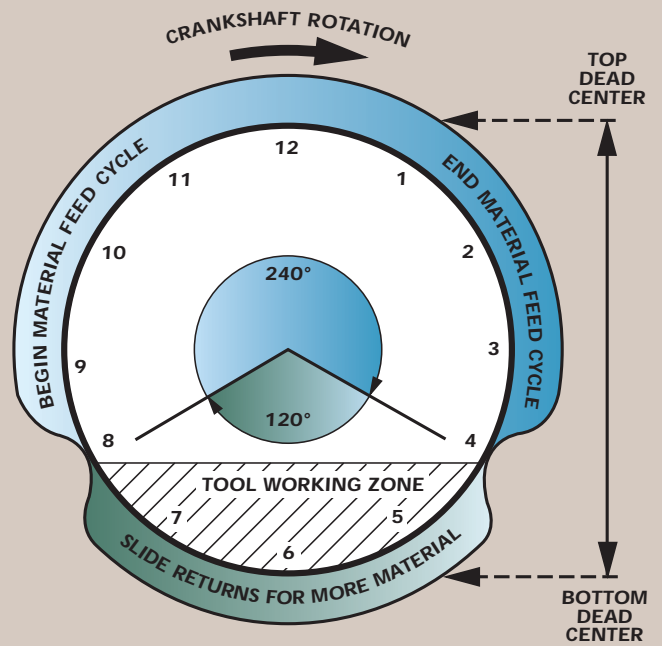

FEEDING SHAPED MATERIAL

The Feed and Stock Clamps can be modified by machining to accommodate different material shapes and configurations. Round or square tubing, wire, or any pre-stamped product like electrical terminals and contacts can be easily handled.

Damage to delicate, pliable materials can be avoided by inserting leather, rubber or nylon into the machined clamps.

You can fabricate oversized clamps for special materials such as channel, extrusions, bars and other irregularly shaped materials.

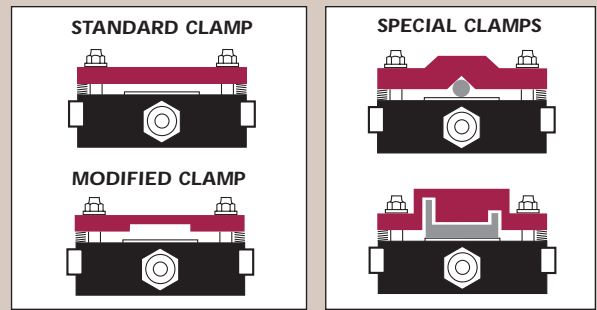

AIR FEED SEQUENCE

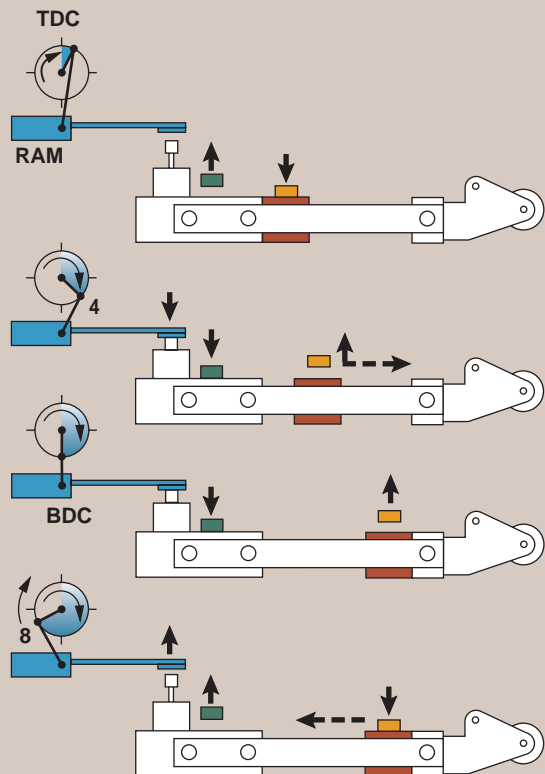

Actuating Valve up
Feed Slide forward
Stock Clamp open
Feed Clamp closed

AT TOP
OF
PRESS
STROKE

Actuating Valve down
Stock Clamp closes
Feed Clamp opens
Feed Slide moves back

AT BEGINNING
OF
NON-FEED
STROKE

Feed Slide rests against Stop Screw
Stock Clamp closed
Feed Clamp open

AT END
OF
NON-FEED
STROKE

Actuating Valve up
Feed Clamp closes
Stock Clamp opens
Feed Slide moves forward

AT BEGINNING
OF
FEED
STROKE

METHODS OF CONTROLLING THE FEED

1. MECHANICAL ACTUATION

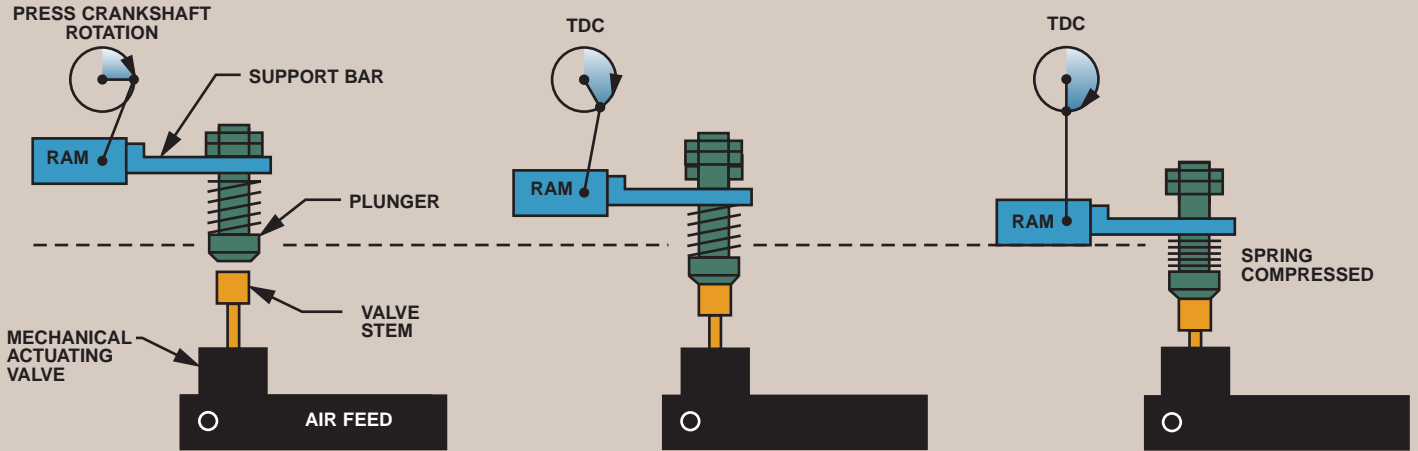

2. REMOTE PNEUMATIC ACTUATION

LINEAR CAM OPERATION

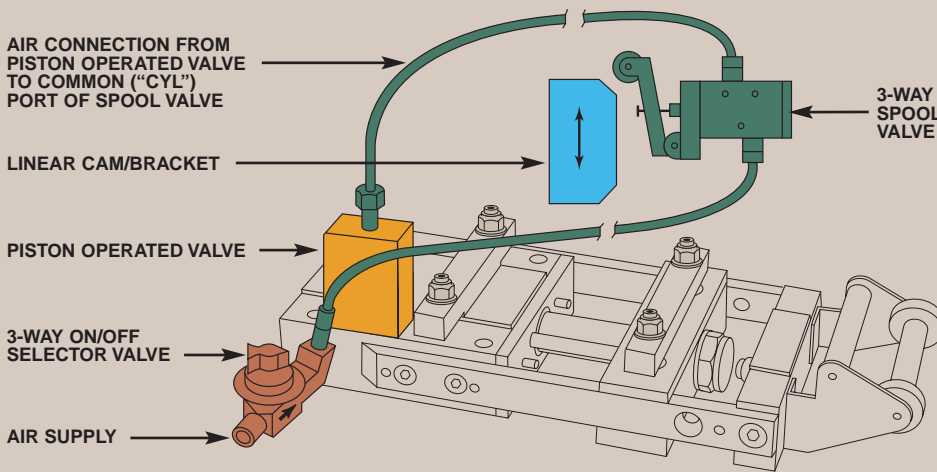

ROTARY CAM OPERATION

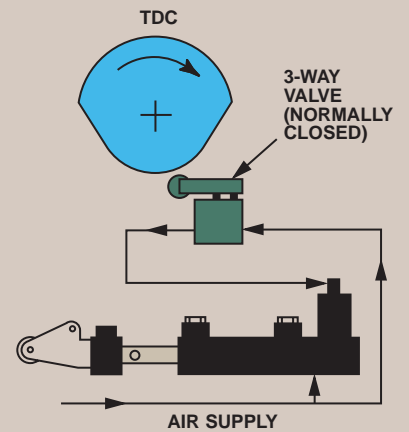

3. REMOTE ELECTRIC ACTUATION

LINEAR CAM OPERATION

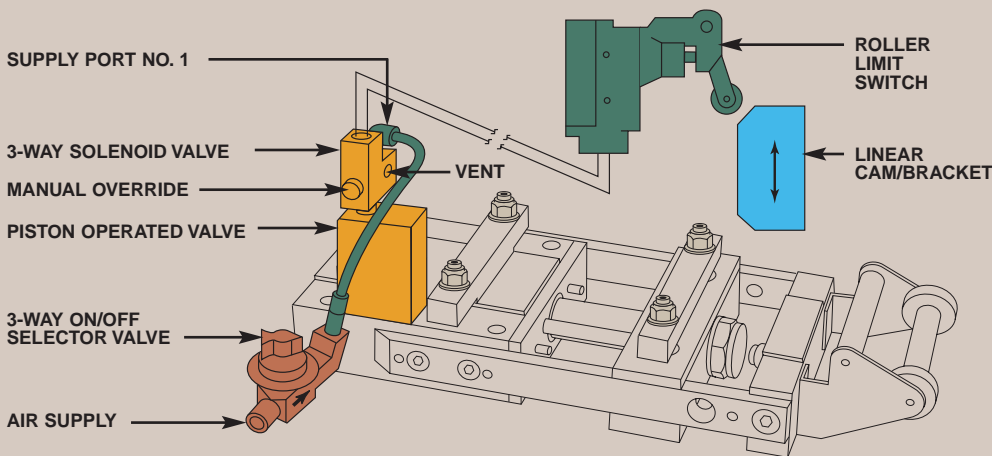

ROTARY CAM OPERATION

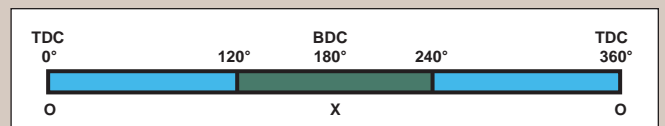
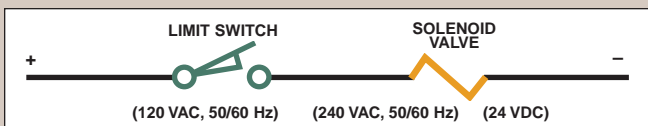
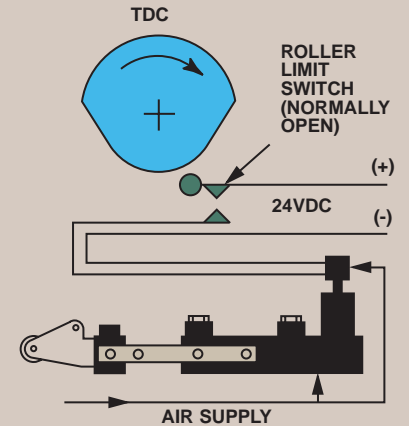

HEAVY DUTY AIR FEED

After a decade of research, this revolutionary feeding device was introduced in 1992 by P/A, the world leader in developing high performance, low maintenance, precision Air Feeds.

The compact construction utilizes a **patented, automatic control** that synchronizes all feeding functions with a momentary signal from a limit switch.

The Heavy Duty Air Feed was computer designed with the latest pneumatic technology for optimal performance and is protected by U.S. Patents No. 4,329,897, No. 4,140,261, and No. 5,125,550.

This feed represents the latest generation of advanced technology for heavy duty performance and low maintenance.

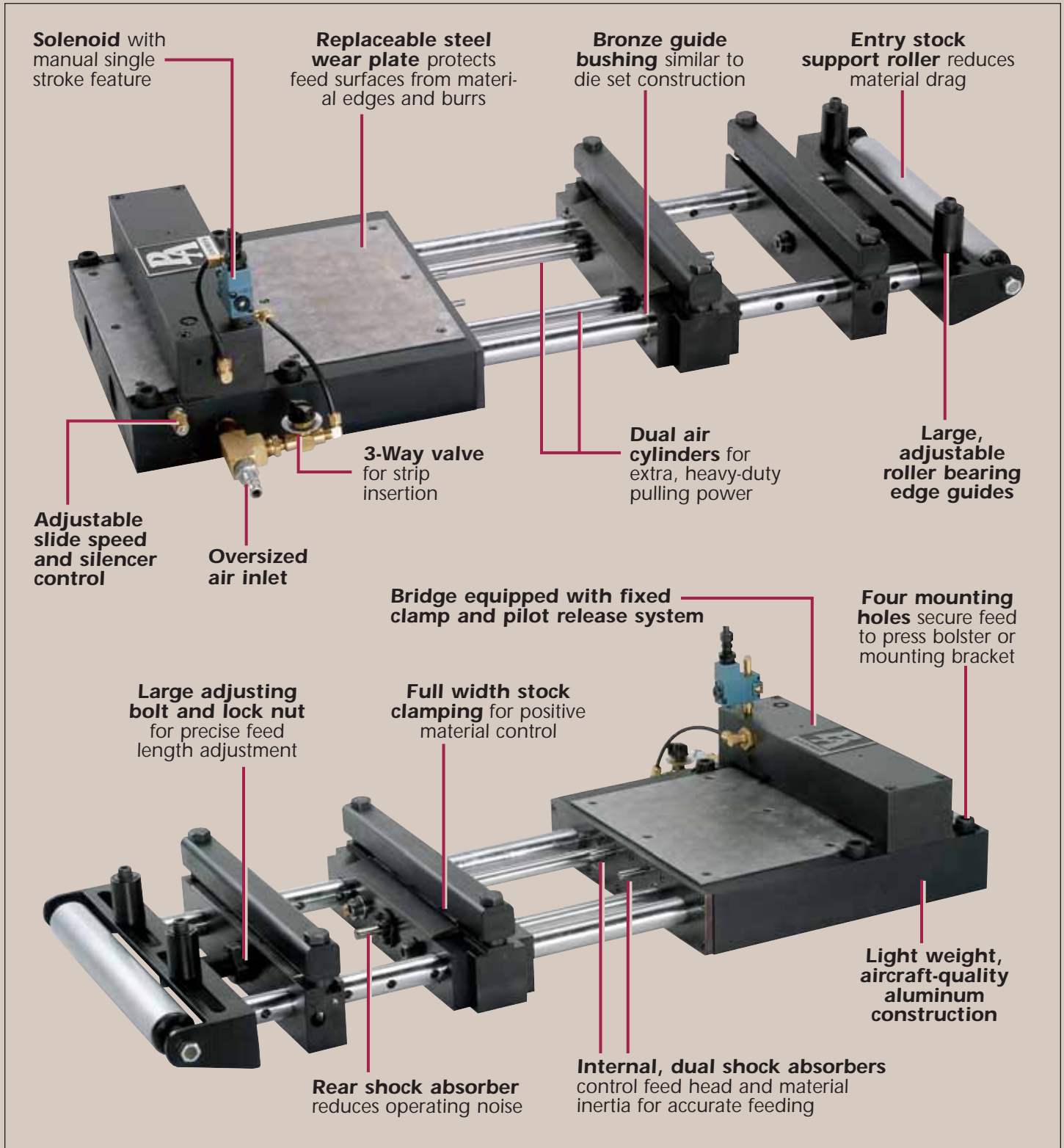

HEAVY DUTY AIR FEED DIMENSIONS & SPECIFICATIONS

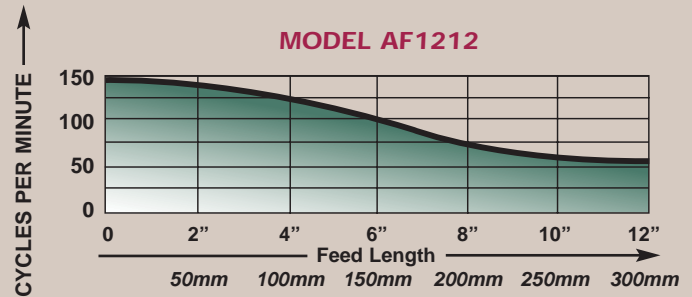
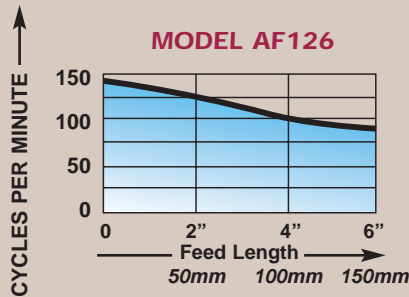
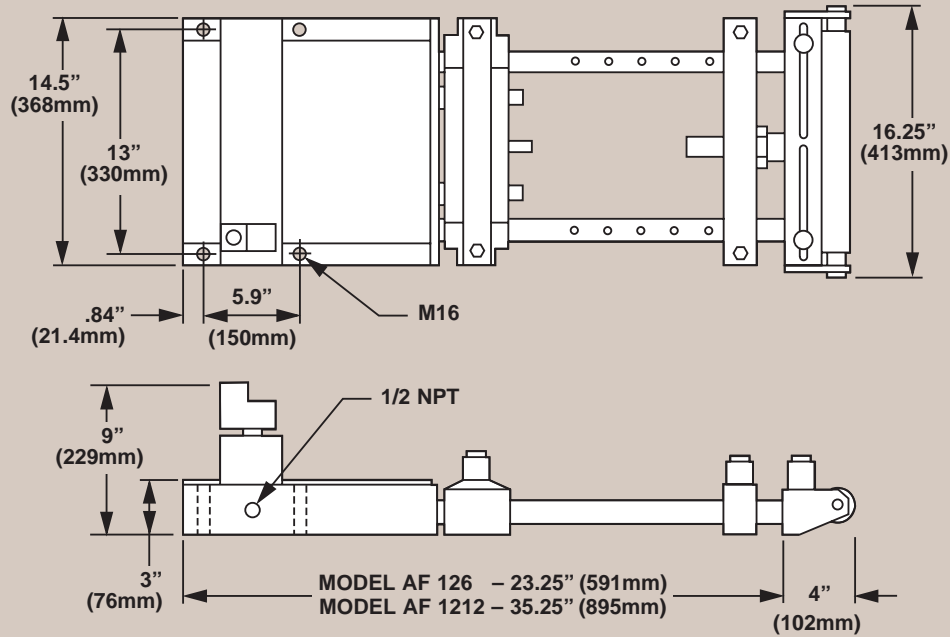

SPECIFICATIONS - USA

Model	Max. Stock Width (In.)	Feed Length (In.)	Pulling Power Note 1 (Lbs.)	Max. Stock Thickness Note 2 (In.)	Feed Grip Force (Lbs.)	Fixed Clamp Force (Lbs.)	Speed Note 3 (SPM)	Air Consumption Per Cycle (CF)	Shipping Weight (Lbs.)
AF126	12	0-6	295	.128	1200	330	85	.023	135
AF1212	12	0-12	295	.128	1200	330	65	.035	155

SPECIFICATIONS - METRIC

Model	Max. Stock Width (mm)	Feed Length (mm)	Pulling Power Note 1 (Kg)	Max. Stock Thickness Note 2 (mm)	Feed Grip Force (Kg)	Fixed Clamp Force (Kg)	Speed Note 3 (SPM)	Air Consumption Per Cycle (CF)	Shipping Weight (Kg)
AF126	300	0-150	135	3.25	565	150	85	0.60	65
AF1212	300	0-300	135	3.25	565	150	65	0.90	70

Note 1: Recommended operating pressure 80 – 120 PSI (6 – 8 Bar).

Note 2: Maximum clearance .150" (3.8mm).

Note 3: Approximate speed at maximum feed length with light weight material. Speed will decrease as the weight of cross sectional strip area being fed increases.

AIR FEED ACCESSORIES

PROTECTIVE COVER

P/A Industries **strongly recommends** our see-through cover of Plexiglas or expanded metal for operator protection. Pre-drilled holes in the Guide Rail accept the Slip-Fit Fasteners that secure the Cover over the top and sides of the Feed. The Protective Cover further protects the Feed from dirt, oil, chips, and other harmful materials.

AX, CX, DX, and FX models are Plexiglas while HX and LX models are made of rugged, expanded metal.



COIL SET ELIMINATOR

The Coil Set Eliminator uses a unique method of removing the natural curve from coiled materials. Steel mills use the same principle of bending the material beyond its yield point to remove the set. This is different from conventional stock straighteners. These inexpensive units can be mounted on the back of any type of press feed and require very little pulling power. Specify material width and thickness with order. Note: This unit is not recommended for material thickness greater than .030" (0.7mm).



WIRE FEED

The installation of stainless steel telescoping tubes with specially sized guide bushings, enable the Air Feed to carry wire smoothly and accurately to the machine. Whip and buckling problems disappear when using the Wire Feed for round, or nearly round materials, over both long and short progressions. Used on AX and CX models only. Wire Straightener sold separately.

Model	Bushing Size (In.)	Max. Feed Length (In.)	Bushing Size (mm)	Max. Feed Length (mm)
AX2	.014 - .023	1.750	0,35-0,59	44
AX2	.024 - .035	1.750	0,60-0,89	44
AX2	.036 - .059	1.750	0,90-1,50	44
AX4	.014 - .023	3.500	0,35-0,59	89
AX4	.024 - .035	3.500	0,60-0,89	89
AX4	.036 - .059	3.500	0,90-1,50	89
AX6	.014 - .023	5.375	0,35-0,59	136
AX6	.024 - .035	5.375	0,60-0,89	136
AX6	.036 - .059	5.375	0,90-1,50	136
CX3	.036 - .059	2.625	0,90-1,50	66
CX3	.060 - .090	2.625	1,50-2,29	66
CX3	.085 - .132	2.625	2,15-3,35	66
CX6	.036 - .059	5.500	0,90-1,50	139
CX6	.060 - .090	5.500	1,50-2,29	139
CX6	.085 - .132	5.500	2,15-3,35	139
CX9	.036 - .059	8.000	0,90-1,50	203
CX9	.060 - .090	8.000	1,50-2,29	203
CX9	.085 - .132	8.000	2,15-3,35	203
CX12	.036 - .059	11.375	0,90-1,50	289
CX12	.060 - .090	11.375	1,50-2,29	289
CX12	.085 - .132	11.375	2,15-3,35	289

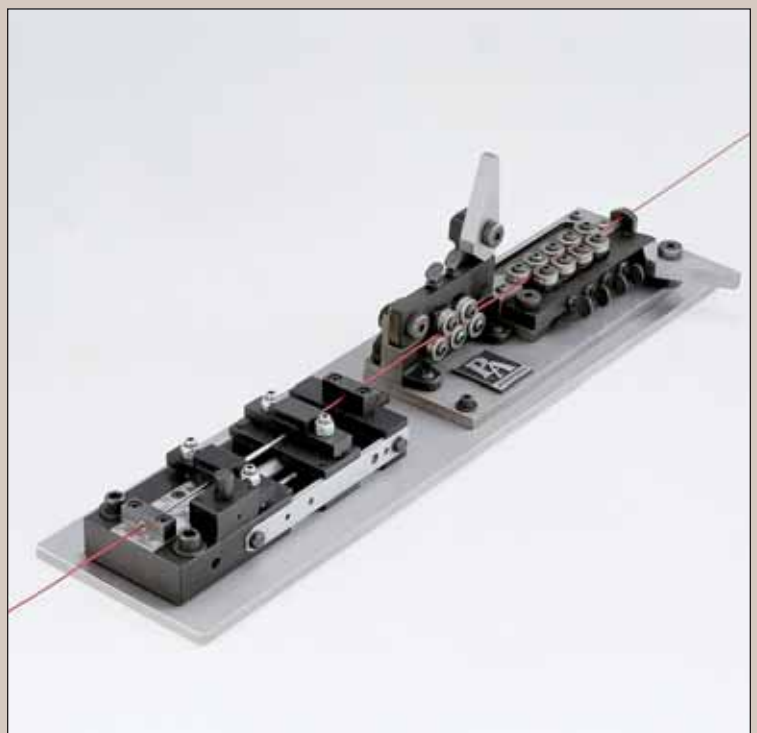

AIR FEED ACCESSORIES

3-WAY ON/OFF EXHAUST VALVE

The use of a 3-Way On/Off Exhaust Valve will make minor adjustments and strip insertion easier.

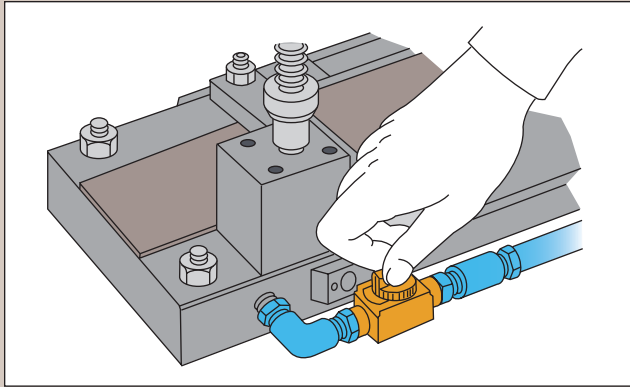

FILTER/REGULATOR/LUBRICATOR

The Filter/Regulator/Lubricator (FRL) supplies clean filtered air, regulates pressure, and provides oil mist lubrication for maintenance-free operation.

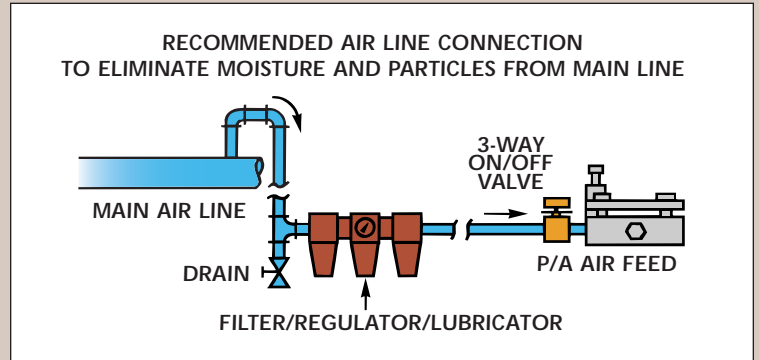

PILOT RELEASE METHODS

Mechanical Pilot Release

Standard on P/A Air Feeds, this Adjustable Spring Clamp provides pressure to the material, holding it until the pilot pin pulls into the position. Note: Not available on LX models.

Pneumatic Pilot Release

For those applications that require more sensitive clamping pressure, or that the Clamp pad be completely free of the material, use the Pneumatic Pilot Release with all P/A Air Feeds. The Clamp Pad is fitted with a quick-response cylinder for positive stock grip and release. Timing is controlled by a 4-Way Solenoid Valve or Spool Valve.

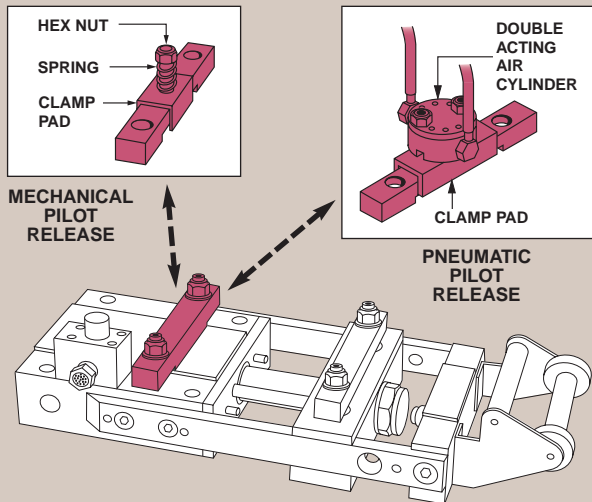

Internal Pilot Release

This internal valving system provides up to 270 lbs. (120 Kg) of clamping force with the standard clamp and is available on the LX model. The Internal Pilot Release controls the release of the Stock Clamp with a timed air signal connected to the 1/8" NPT port. This feature gives you the option of using pilot release, or not, without the downtime necessary for changing clamps. One switch turns the system on or off.

SLIM LINE STOCK OILER

A Gravity Fed Stock Oiler can be mounted on the main body of the Feed to apply stamping and drawing oils to the material as it is fed into the die. When you apply an even coat of oil on the strip after the material passes through the feed clamps, the misfeeding caused by hydroplaning is avoided. The Slim Line Oilers were designed specifically for our Air Feeds and come with feed mounting brackets for CX, DX, FX, and HX Models.

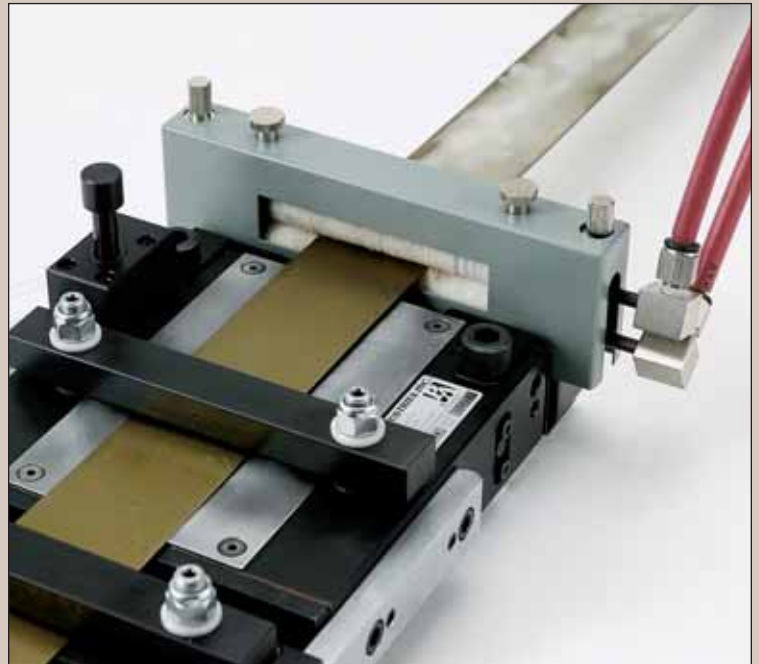

REPEATER CONTROL SYSTEM

The Air Feed can be multiple stroked for each cycle of the Press to obtain greater feed length increments than the Air Feeds maximum feed stroke capacity. The Repeater Control has a digital counter and Key Lock Selector Control for Feed Control Press" or "Press Control Feed". Used with Remote Electric Actuation and 120 VAC, 50/60 Hz Power Supply. Transformers for other voltages are available.

BAND FEED

Over two decades ago, P/A engineers came up with this innovative approach to solving the problems of indexing very limp and delicate materials. Material such as foil, film, paper, fabric, mylar, and teflon are easily handled by the Band Feed.

Thin, delicate material is sandwiched between two endless belts which the Air Feed then clamps and feeds. Marking, tearing, and buckling are completely eliminated while moving the material into, or out of, the work station accurately — cycle after cycle.

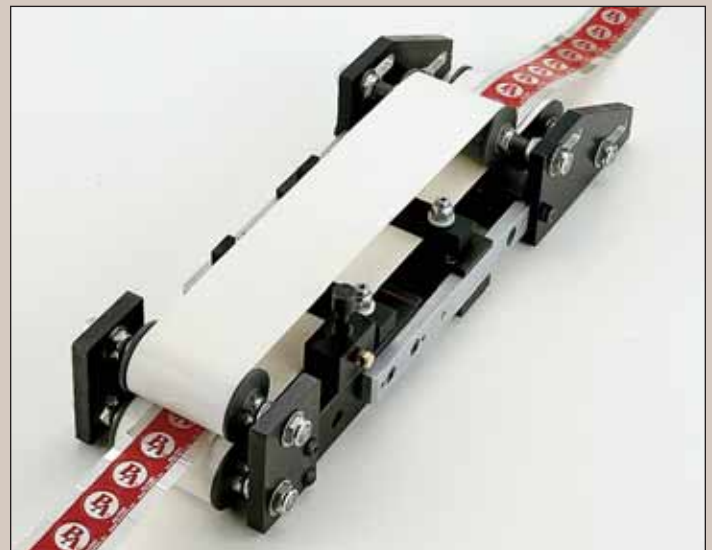

SPECIFICATIONS – USA				
Model	Width (In.)	Length (In.)	Pulling Force (Lbs.)	Speed (SPM)
BFCX3	3	3	50	180
BFCX6	3	6	50	120
BFCX9	3	9	50	80
BFCX12	3	12	50	70
BFFX6	6	6	110	100
BFFX9	6	9	110	70
BFFX12	6	12	110	60
BFHX6	9	6	110	80
BFHX12	9	12	110	50

SPECIFICATIONS – METRIC				
Model	Width (In.)	Length (In.)	Pulling Force (Lbs.)	Speed (SPM)
BFCX3	76	76	23	180
BFCX6	76	150	23	120
BFCX9	76	230	23	80
BFCX12	76	300	23	70
BFFX6	150	150	50	100
BFFX9	150	230	50	70
BFFX12	150	300	50	60
BFHX6	230	150	50	80
BFHX12	230	300	50	50

STOCK OILER



The Stock Oiler has been designed to accommodate any type or thickness of material. Its revolutionary roller assembly pivots to accommodate material movement and crown, camber, or unstraightened stock.

Any kind of liquid lubricant is evenly distributed to the absorbent felt roller by a predrilled PVC inner tube that rides in an oil bearing bath.

Oil flow to each roller is individually controlled by metering valves which are installed on a reservoir tank that is equipped with an oil level gauge.

Adjustable tension springs help to apply the right oil film by supplying enough pressure to squeeze off any excess which is then recycled to the unit.

Mounting the compact Stock Oiler between the press feed and tool is easily done by attaching a magnet on the steel base, or drilling two holes. Two wing nuts allow for quick pass line height adjustment to suit different tools.

The use of the Stock Oiler increases die life and eliminates the "coffee-can" mess which makes your operation safer and more efficient.

OIL FLOW SYSTEM

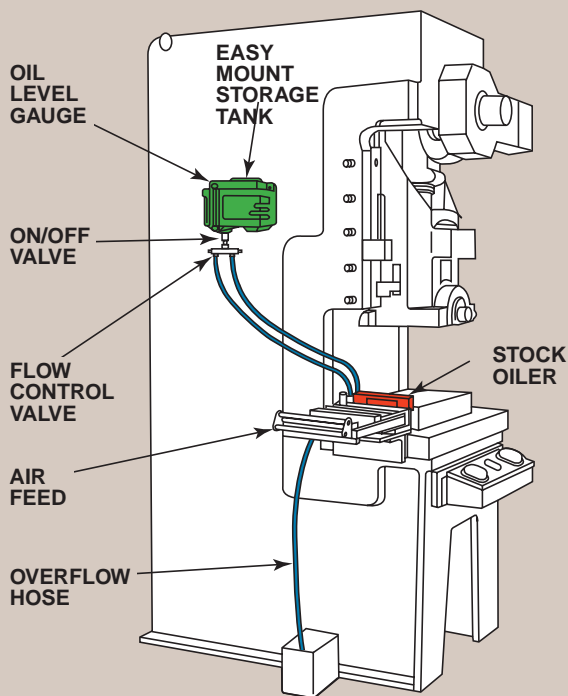

OIL FLOW TO ROLLER

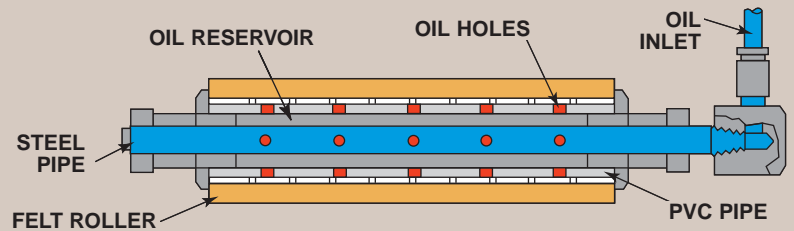

DIMENSIONS

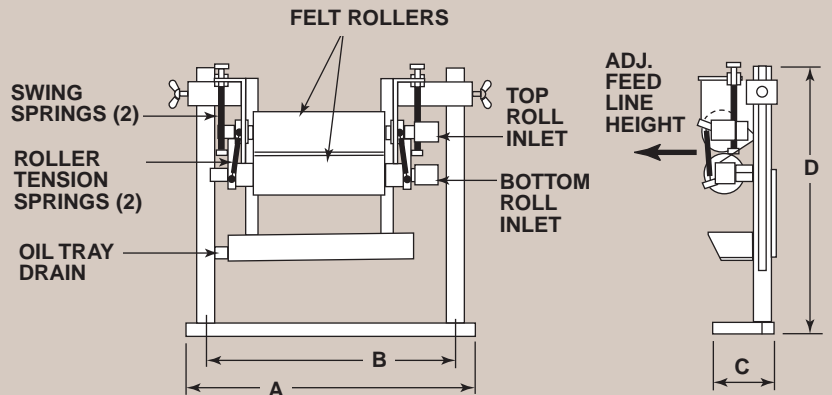

SPECIFICATIONS - USA

Model	Max. Stock Width (In.)	Thickness Range (In.)	Tank Size (Gal.)	Shipping Weight (Lbs.)	Shipping Weight with Tank (Lbs.)	Dimensions (Inches)			
						A	B	C	D
SO-100	4	.001 - .187	1	7	11	9.25	7.97	2	7.87
SO-200	8	.001 - .187	1	8	12	13.07	11.87	2	9.84
SO-300	12	.001 - .187	1	10	14	17.20	16.00	2	9.84
SO-400	16	.001 - .187	1	12	16	21.06	19.90	2	9.84
SO-600	24	.001 - .187	1	16	20	29.13	27.93	2	9.84

SPECIFICATIONS - METRIC

Model	Max. Stock Width (mm)	Thickness Range (mm)	Tank Size (Ltr)	Shipping Weight (Kg)	Shipping Weight with Tank (Kg)	Dimensions (mm)			
						A	B	C	D
SO-100	100	0.03 - 4.68	3.8	3.2	5.0	235	202	51	200
SO-200	200	0.03 - 4.68	3.8	3.6	5.4	332	301	51	250
SO-300	300	0.03 - 4.68	3.8	4.5	6.4	437	406	51	250
SO-400	400	0.03 - 4.68	3.8	5.4	7.3	535	505	51	250
SO-600	600	0.03 - 4.68	3.8	7.3	9.1	740	709	51	250

ROLLERLUBE



This efficient material lubrication system roller coats incoming stock with a film of oil without mess and waste. It eliminates hand brushing or drip methods. Controlled flow of lubricant reduces die wear and flushes foreign material from stock.

Four rollers squeeze off excess oil which is drained and filtered into a storage tank to be recycled and used again.

A sight gauge, low-level warning indicator assures a continuous flow of lubricant. The pump can handle stamping oils, as well as water soluble oils.

This system has the ability to regulate and apply an oil film on the top surface only, bottom surface only, or both sides. Rubber rolls can be supplied for special finish materials in place of steel rolls.

THREE METHODS TO APPLY LUBRICANT

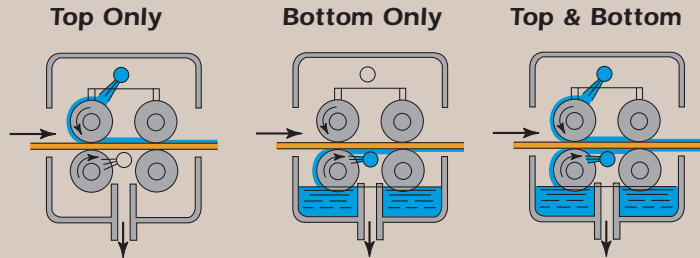

STORAGE TANK

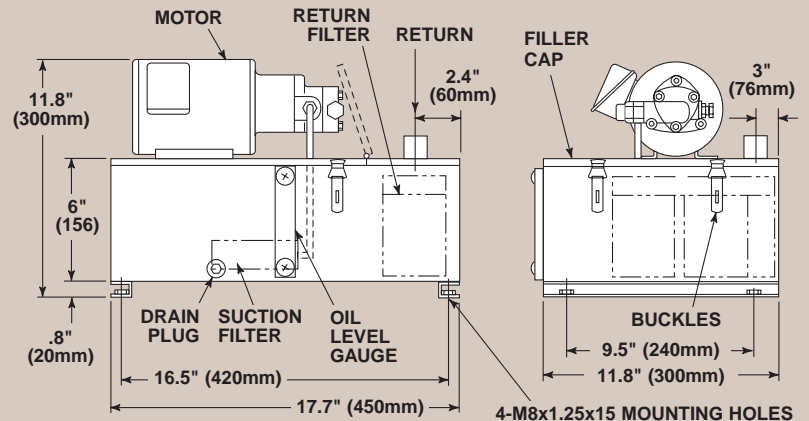

DIMENSIONS

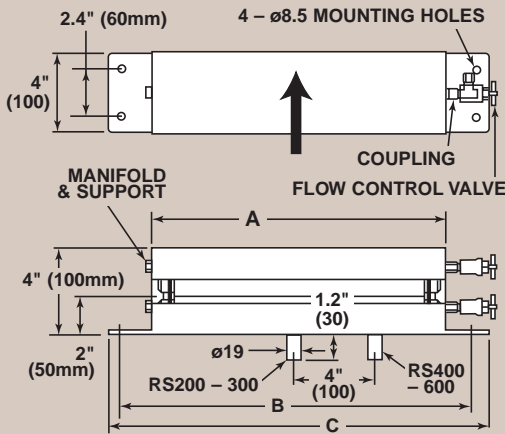

Model	DIM. - Inches			DIM. - Metric		
	A	B	C	A	B	C
RL-200	11	14	15	280	360	390
RL-300	15	18	19	380	460	490
RL-400	19	22	23	480	560	590
RL-600	27	30	31	680	760	790

SPECIFICATIONS - USA

Model	Steel Rolls	Stock Width (In.)	Max. Thickness (In.)	Tank Size (Gal.)	Pump Discharge (GPM)	Input Power Voltage/Phase/Hz
RL-200	4	8	.187	5	.71	110/1/60
RL-300	4	12	.187	5	.71	110/1/60
RL-400	4	16	.187	5	.71	110/1/60
RL-600	4	24	.187	5	.71	110/1/60

SPECIFICATIONS - METRIC

Model	Steel Rolls	Stock Width (mm)	Max. Thickness (mm)	Tank Size (Ltr.)	Pump Discharge (LPM)	Input Power Voltage/Phase/Hz
RL-200	4	220	4.8	20	2.7	220/1/50
RL-300	4	320	4.8	20	2.7	220/1/50
RL-400	4	420	4.8	20	2.7	220/1/50
RL-600	4	600	4.8	20	2.7	220/1/50

Note: Add S or R to Model for Steel or Rubber Rolls. Example: RL200S for Steel Rolls.
Add 1 for 110 volt and 2 for 220 volt. Example: RL200R2 for Rubber Rolls with 220 volt.

SLIM LINE OILER



Improve die life by applying the right amount of oil just before the material enters the die set. Clean up the press area by installing "Slim Line" gravity fed stock oilers.

A durable storage tank mounts to the side of the press and is equipped with a liquid sight gauge, screen filter, removable fill lid, on/off valve, and separate flow control valves for top and bottom rollers.

The head assembly is designed for compactness and allows mounting very close to the tool. Oil flow is delivered to predrilled manifolds with extra absorbent felt roller washers providing uniform film on coil stock. Upper roll pressure is applied by adjustable springs. Overflow return line handles excess oil which is then reusable.

OIL STORAGE TANK



DIMENSIONS

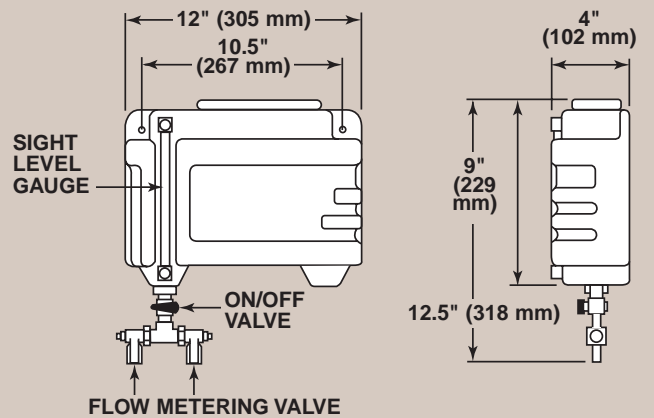
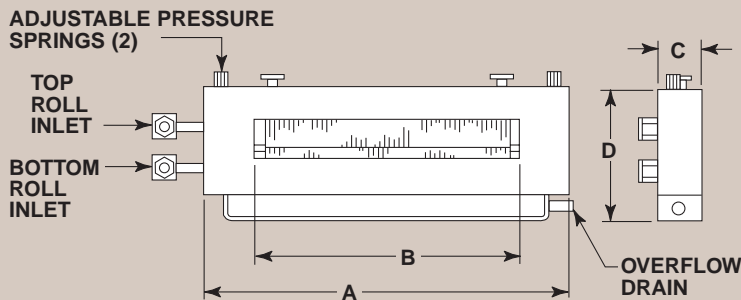

SPECIFICATIONS – USA							Dimensions (Inches)			
Model	Max. Stock Width (In.)	Thickness Range (In.)	Tank Size (Gal.)	Shipping Weight (Lbs.)	Shipping Weight with Tank (Lbs.)	A	B	C	D	
SL-100	4	.001 – .060	1	8	12	8	4.5	1	3.5	

SPECIFICATIONS – METRIC						Dimensions (mm)			
Model	Max. Stock Width (mm)	Thickness Range (mm)	Tank Size (Ltr)	Shipping Weight (Kg)	Shipping Weight with Tank (Kg)	A	B	C	D
SL-100	100	0.03 – 1.50	3.8	3.6	5.4	203	114	25	89

MECHANICAL SCRAP CHOPPER



The P/A Scrap Chopper has a unique helical-ground blade which chops a wide variety of materials from .004" (0.1mm) paper to 3/16" (4.8mm) CRS without adjustment. Once installed, any number of stock thicknesses and widths can be fed into the chopper without any additional set-up time.

With a P/A Scrap Chopper mounted on your machine, you eliminate the need for air blow-offs, sheet metal chutes, conveyors and rakes used by operators to get the scrap out of the tool area and into containers.

Providing one chopper per press can save the cost of designing and building guillotine choppers for every die.

Rugged cast iron construction with few moving parts assures maintenance-free production. The Reel-Type scissor action reduces off center loading by chopping a width of only 14 times the maximum material thickness at one time regardless of total stock width.



DIMENSIONS

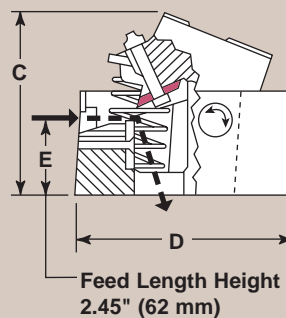
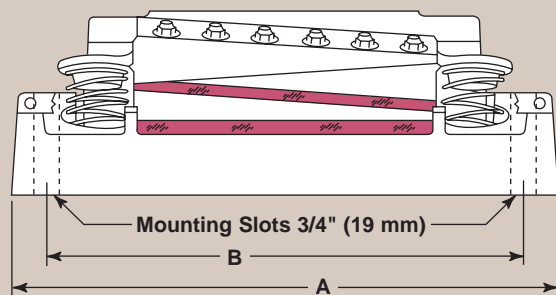

ROLLER ACTIVATION

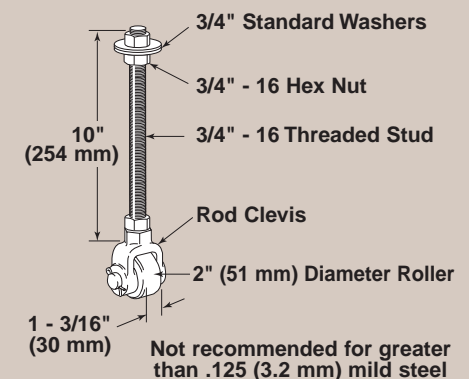

SPECIFICATIONS - USA

Max. Stock Model	Stock Thickness Width (In.)	Max. SPM Range (In.)	Shipping Full Width	Weight (Lbs.)	Dimensions (In.)				
					A	B	C	D	E
SC-3	3	.004 - .187 CRS	750	45	10.6	8.5	5.75	6.8	2.45
SC-6	6	.004 - .187 CRS	650	52	13.6	11.5	5.84	6.8	2.45
SC-9	9	.004 - .187 CRS	550	60	16.6	14.5	5.94	6.8	2.45
SC-12	12	.004 - .187 CRS	450	68	19.6	17.5	6.03	6.8	2.45

SPECIFICATIONS - METRIC

Max. Stock Model	Stock Thickness Width (mm)	Max. SPM Range (mm)	Shipping Full Width	Weight (Kg)	Dimensions (mm)				
					A	B	C	D	E
SC-3	76	0.1 - 5.0 CRS	750	20	269	216	146	173	62
SC-6	152	0.1 - 5.0 CRS	650	24	345	292	148	173	62
SC-9	229	0.1 - 5.0 CRS	550	27	422	368	151	173	62
SC-12	305	0.1 - 5.0 CRS	450	31	498	445	153	173	62

MOTORIZED SCRAP CHOPPER



These motor driven, self-contained Scrap Choppers work best with double roll feed applications, or where choppers are inconvenient on the press frame.

Easily moved from press to press, the Chopper has the ability to handle a wide range of materials.

High carbon, high-chrome steel blades can be adjusted to efficiently handle different stock thicknesses. Blade removal and regrinding to maintain sharpness is easily performed.

Floor height is adjustable and the chopper head pivots to accept natural flow of skeleton. Scrap pieces fall into a container positioned between the legs, saving floor space. Entry and exit guide chutes minimize scrap handling and maintain a clean work area.

DIMENSIONS

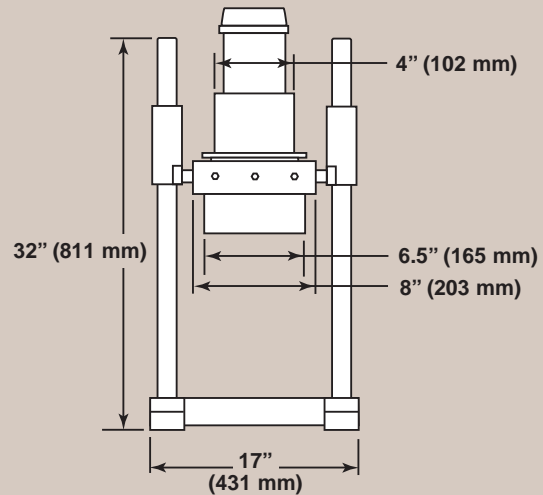
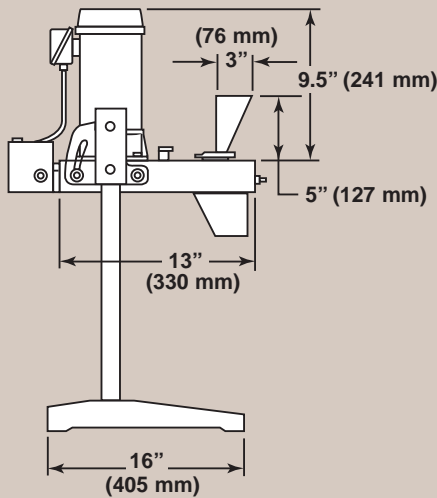

SPECIFICATIONS – USA

Model	Max. Stock Width (In.)	Max. Stock Thickness (In.)	Cutting Speed (SPM)	DC Drive Motor (HP)	Input Power Voltage/Phase/Hz	Shipping Weight (Lbs.)
MSC100	4	.050 CRS	85	1/4	110/1/50-60 220/3/50-60	120

SPECIFICATIONS – METRIC

Model	Max. Stock Width (mm)	Max. Stock Thickness (mm)	Cutting Speed (SPM)	DC Drive Motor (KW)	Input Power Voltage/Phase/Hz	Shipping Weight (Kg)
MSC100	101	1.1 CRS	85	.19	220/3/50 380/3/50	54

Note: Specify VAC Gear Motor.

AIR SCRAP CHOPPER



Using the same principle as our Ram Driven Scrap Chopper, this pneumatically powered chopper is designed to shear scrap material from .004" (0.1mm) to .074" (1.8mm) thick mild steel.

A powerful, double acting air cylinder provides controlled chopping while integral dampeners absorb snap through shock. The helically ground upper blade, made of high chrome tool steel, shears any kind of material.

A four-way solenoid valve controls the sequencing and can be synchronized with any machine by a limit switch, proximity sensor or programmable rotary limit switch. If a timing relay or counter is used, every other press stroke operation is possible for longer scrap pieces or extremely high speed operations. (Guard removed for photo)

DIMENSIONS

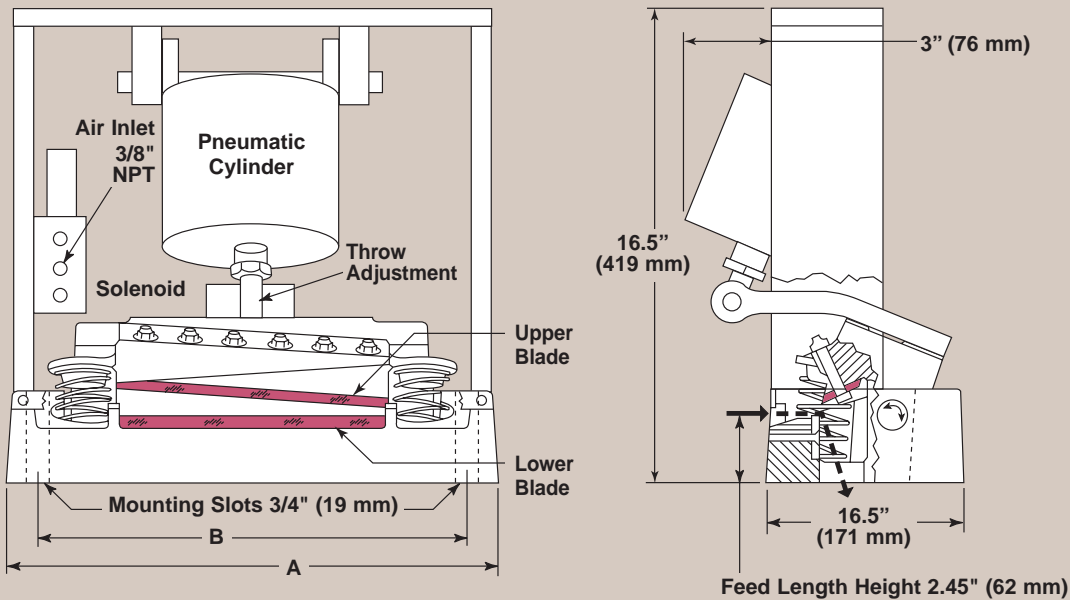

Model	A	B
DIMENSIONS. – Inches		
ASC-6	13.6	11.5
ASC-9	16.6	14.5
ASC-12	19.6	17.5
DIMENSIONS. – Metric		
ASC-6	345	292
ASC-9	422	368
ASC-12	498	445

SPECIFICATIONS – USA

Model	Max. Stock Width (In.)	Stock Thickness Range (In.)	Max. Force (Lbs.) at 100 PSI	Max. Cycles/Min. No Load	Air Consumption at Max. SPM and 100 PSI	Shipping Weight (Lbs.)
ASC-6	6	.004 – .074 CRS	2800	200	72 CFM	80
ASC-9	9	.004 – .074 CRS	2800	190	66 CFM	90
ASC-12	12	.004 – .074 CRS	2800	180	73 CFM	100

SPECIFICATIONS – METRIC

Model	Max. Stock Width (mm)	Stock Thickness Range (mm)	Max. Force (N) at 6.8 Bar	Max. Cycles/Min. No Load	Air Consumption at Max. SPM and 6.8 Bar	Shipping Weight (Kg)
ASC-6	152	0.1 – 1.8 CRS	12500	200	34 dm ³ /s	36
ASC-9	228	0.1 – 1.8 CRS	12500	190	31 dm ³ /s	40
ASC-12	305	0.1 – 1.8 CRS	12500	180	34 dm ³ /s	45

Note: Solenoid Voltage is 120 VAC, Single Phase, 50/60 Hz. Other voltages available – 240 VAC, 24 VDC.

PNEUMATIC STOCK CUTTER



This Stock Cutter is designed to shear material with a clean edge. Fed by a programmable Servo Feed or Air Feed, it can be used in cut-to-length applications. Mounted on a press, it can be used as a scrap cutter or part cutoff.

Pneumatically powered, these stock cutters are designed to shear material at full width. The powerful three-stage, double acting air cylinders have a pancake profile for high speed operation. Integral stroke dampeners are used to handle snap-through shock loads, extending cycle life.

The four-way solenoid valve controls the sequencing and can be synchronized with a press. If a timing relay or counter is used, every other press stroke operation is possible for longer scrap pieces or work with high speed operations.

The compact, low profile construction allows for easy mounting and, if desired, portability.

Each cutter is equipped with air silencers and safety guard with fully adjustable material guides as an option.

Both upper and lower blades are vertically adjustable for wear compensation and sharpening. The lower blade is also horizontally adjustable to provide the correct blade clearance necessary to cut different materials. No other stock cutter has both of these features.

DIMENSIONS

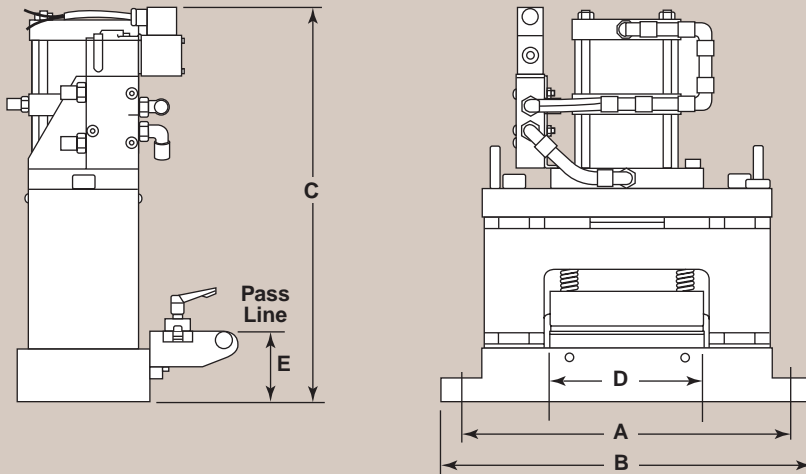

Model	A	B	C	D	E
DIMENSIONS - Inches					
PSC-3	8.00	9.0	13.38	3	2
PSC-6	13.50	15.5	19.68	6	3
PSC-12	19.75	21.5	19.68	12	3
DIMENSIONS - Metric					
PSC-3	203	229	340	76	50
PSC-6	343	387	422	152	76
PSC-12	502	546	422	304	76

SPECIFICATIONS - USA

Model	Max. Stock Width (In.)	Max. Material Thickness at Full Width (In.)			Thickness Range (In.)	Stock Max. Force (Lbs.) at 100 PSI	Air Consumption at Max. SPM and 100 PSI	Shipping Weight (Lbs.)
		Aluminum Brass	C.R. Steel	Stainless Steel				
PSC-3	3	.044	.034	.032	.001 - .045	950	10 CFM	76
PSC-6	6	.063	.046	.044	.001 - .064	2400	27 CFM	92
PSC-12	12	.089	.068	.063	.001 - .090	4800	69 CFM	160

SPECIFICATIONS - METRIC

Model	Max. Stock Width (mm)	Max. Material Thickness at Full Width (mm)			Thickness Range (mm)	Stock Max. Force (N) at 6.8 Bar	Air Consumption at Max. SPM and 6.8 Bar	Shipping Weight (Kg)
		Aluminum Brass	C.R. Steel	Stainless Steel				
PSC-3	76	1.1	0.9	0.8	0.04 - 1.1	4200	5 dm ³ /s	34
PSC-6	152	1.6	1.2	1.1	0.04 - 1.6	10600	13 dm ³ /s	42
PSC-12	305	2.3	1.7	1.6	0.04 - 2.3	21300	32 dm ³ /s	73

Note: Input power is 120 VAC, Single Phase, 50/60 Hz. Other voltages available - 240 VAC, 24 VDC.

TRANSPORTER



The transporter is a unique, pneumatically driven feeder that was designed to solve scrap removal problems efficiently and inexpensively. This BELTLESS CONVEYOR transports the pieces of scrap with a shaking tray motion. A custom tray is fitted onto the body and the rhythmic, linear motion moves the tray slowly forward and then quickly backwards. The metal shavings, scrap, or finished parts are gently shuffled along the tray into a convenient container.

Although air operated, the air consumption is so low that it would be considered insignificant in a press shop environment. The noise level is well under acceptable

standards for industrial uses.

Install the Transporter under any tool and problems with slugs, steel shavings and scrap disappear.

The Transporter costs a fraction of the price of motorized conveyors. The replacement cost of belts and rollers alone justifies the change from conventional conveyors.

Originally developed to remove scrap from presses, the Transporter is now being used in assembly-type operations to move parts.

U.S. PATENT NO.
4,444,346

INSTALLATIONS

Easily installed outside the press area, a TP-10 conveys stamped parts into a shipping container.



This TP-70 powers three metal trays



One TP-40 mounted on the bolster uses an upper tray to remove the chopped skeleton and a lower tray for finished parts.



TRANSPORTER APPLICATIONS

These low profile, beltless conveyors are pneumatically powered. The vibrating, rhythmic motion will transport your parts and scrap and save you money. Trays can be fabricated to suit any size opening and to separate different sized scrap material.

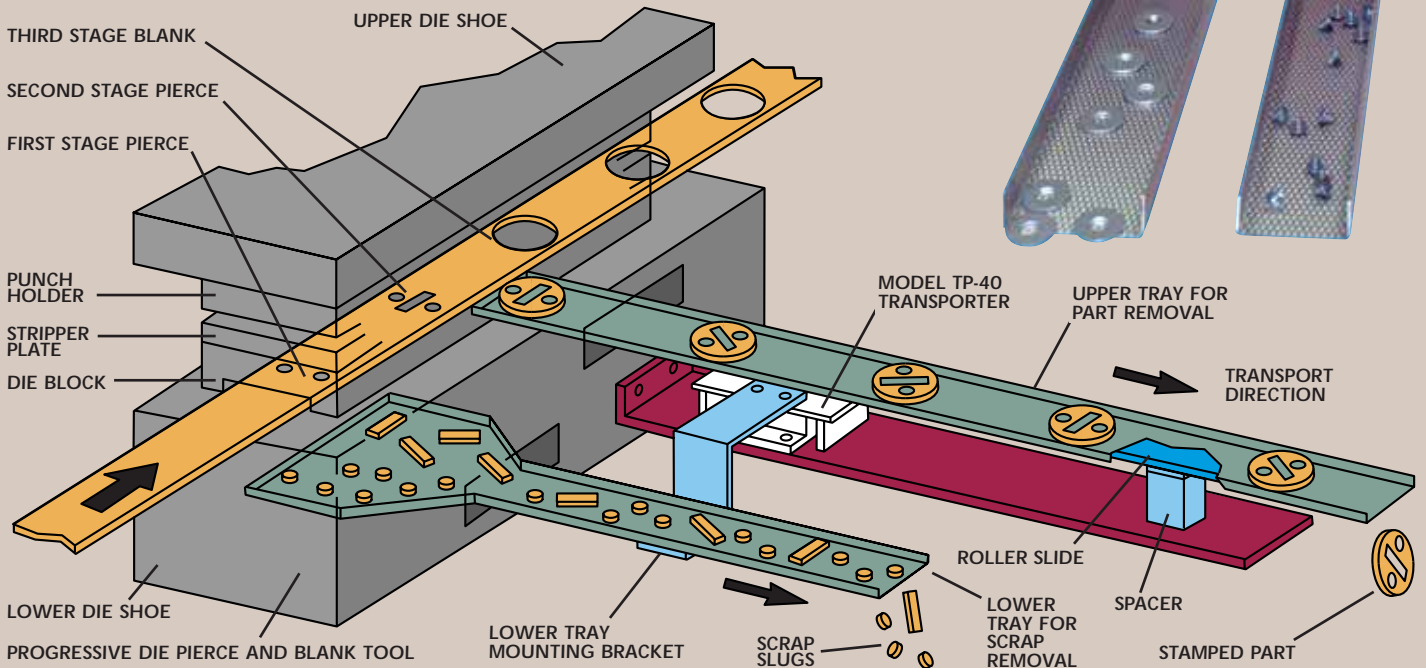
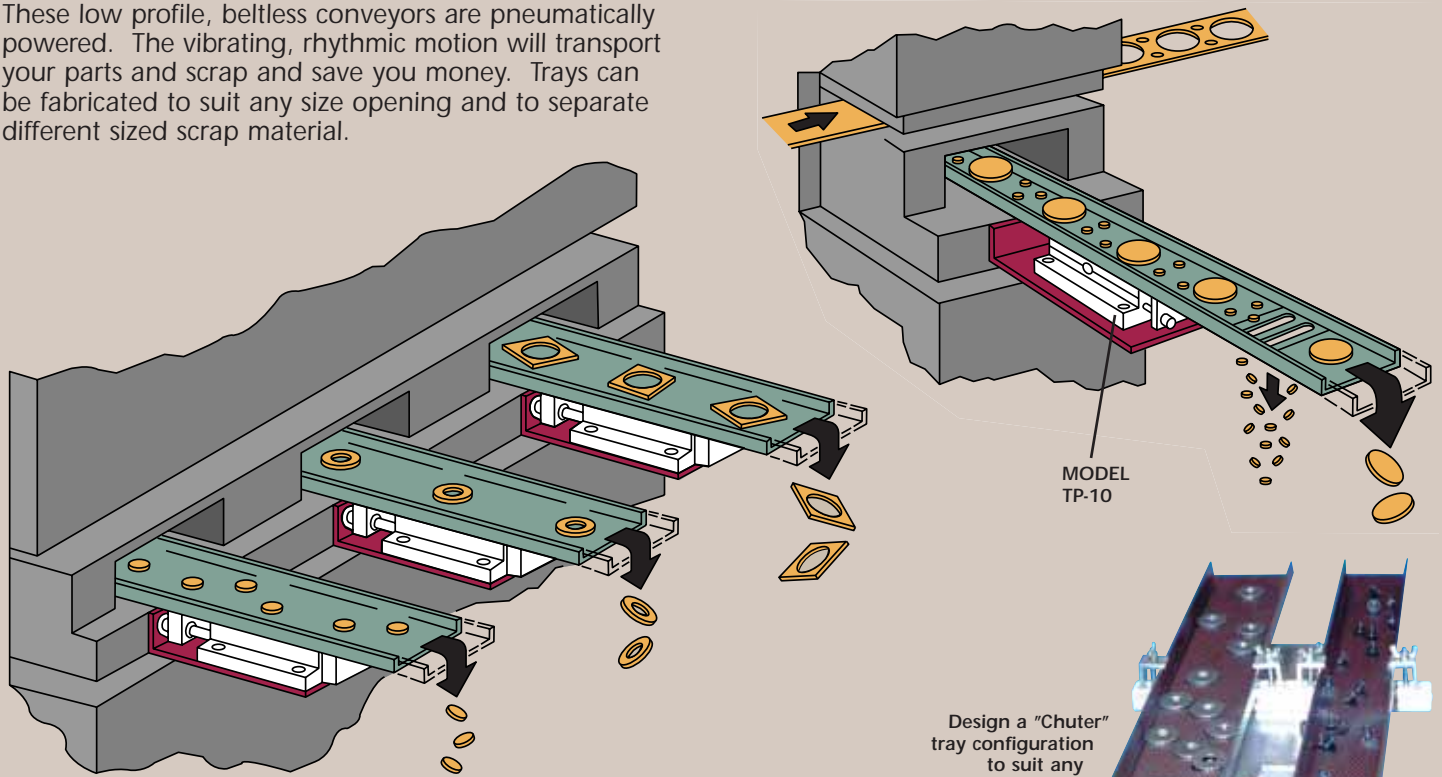

OPTIONAL TRAY SUPPORTS

Three methods for front and rear support of long trays or custom chutes. Recommended materials for low friction solid slides are Delrin (GP500) or Nylon and ball bearings for low rolling resistance.

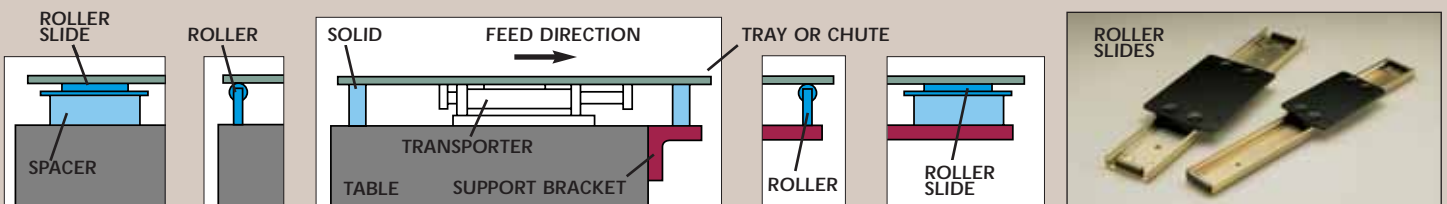

TRANSPORTER DIMENSIONS

Model TP-3

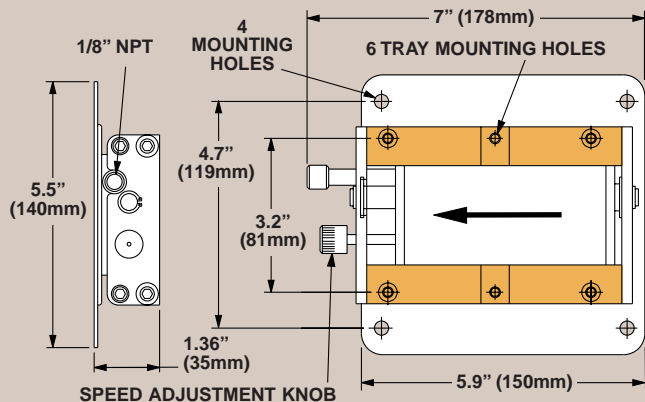

Model TP-10

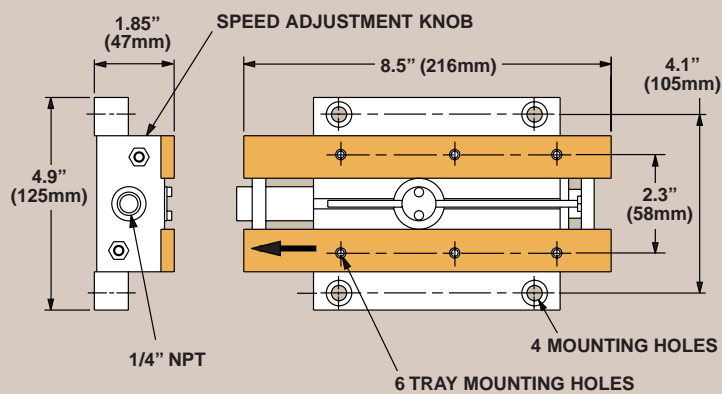

Model TP-40

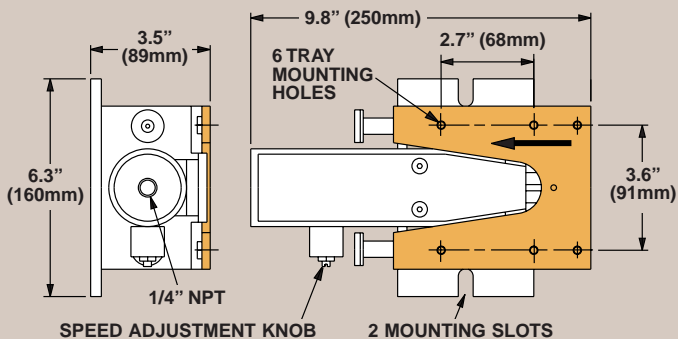

Model TP-70

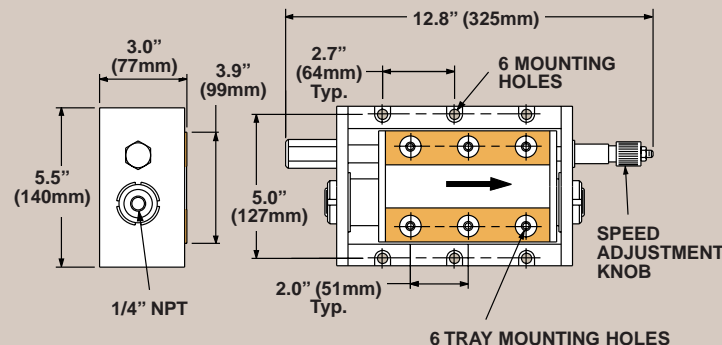

Model TP-140

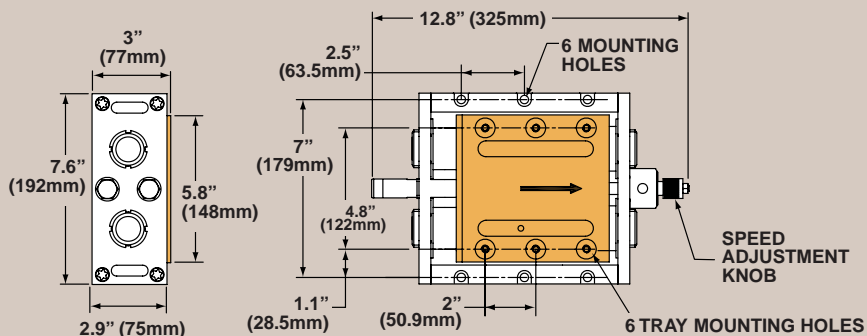

SPECIFICATIONS - USA

Model	Load Capacity with Tray (Lbs.)	Air Consumption (CFM)	Sound Level (db-A)	Stroke Length (in.)	Max. Tray Weight (Lbs.)	Shipping Weight (Lbs.)
TP-3	6	0.5	68	0.91	3	3.5
TP-10	20	0.7	68	0.98	6	7.0
TP-40	80	1.4	70	1.06	12	16.5
TP-70	140	1.4	70	0.98	25	12.5
TP-140	300	2.8	62	0.98	45	17.6

SPECIFICATIONS - METRIC

Model	Load Capacity with Tray (Kg)	Air Consumption (L/Min.)	Sound Level (db-A)	Stroke Length (mm)	Max. Tray Weight (Kg)	Shipping Weight (Kg)
TP-3	3	14	68	23	1,4	1,4
TP-10	10	20	68	25	2,7	2,8
TP-40	40	42	70	27	5,4	7,2
TP-70	70	40	70	25	11,3	5,5
TP-140	140	80	62	25	20,4	8,0

Note: 1. Recommended speed: 120 SPM 2. Feed Rate: 26-34 FPM (8-10 m/min.) 3. Air Pressure Range: 50-75 PSI (4-6 bar) 4. Max. Incline of Tray 8°

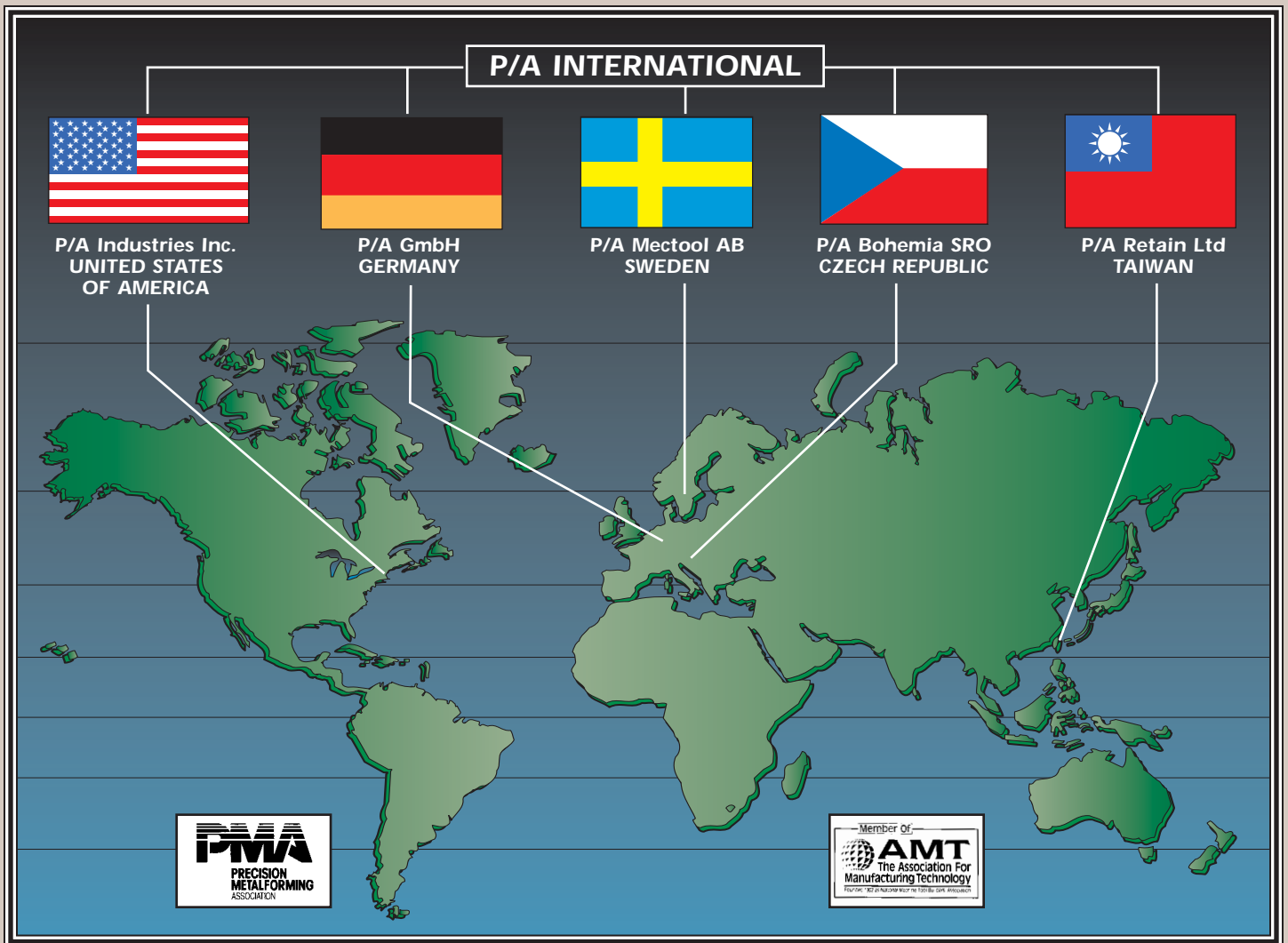

WARRANTY

We warrant our mechanical parts against defects under normal use and service for a period of 2 years after date of shipment. We warrant all components installed, but not manufactured by P/A, for 1 year after date of shipment. Our obligation under this warranty is limited to replacing or repairing (at our option) the defective part without charge, F.O.B. our plant in Bloomfield, Connecticut. The defective part must be forwarded to our plant, freight-prepaid, for our inspection prior to replacement or repair. EXCEPT AS EXPRESSLY PROVIDED HEREIN, THIS WARRANTY IS IN LIEU OF ALL OTHER WARRANTIES, EXPRESS OR IMPLIED, INCLUDING A WARRANTY OF MERCHANTABILITY OR FITNESS FOR A PARTICULAR PURPOSE.

WARNING !

This equipment offers various means of operating metal forming machines, delivers the material or parts to the machine, or removes material, parts, or scrap from the machine. The operators hands must NOT be in or near the point-of-operation of the machine, or the operating parts of any equipment installed on the machine, or bodily injury could result. The EMPLOYER must post adequate warning signs on the press with proper warnings for his machine and the specific application to which the machine and equipment are being applied. If the EMPLOYER requires help in preparing wording for his application after he has determined the details of that application, he is invited to contact P/A Industries for such help.

The EMPLOYER must meet all OSHA regulations including, but not limited to, 1910.211, 1910.147, 1910.212, 1910.217 and all applicable state laws. All equipment manufactured by P/A Industries is designed to meet the construction standards of OSHA in effect at the time of sale, but the EMPLOYER installs the equipment, and therefore the EMPLOYER is responsible for installation, use, application, training, and maintenance, as well as adequate signs on the press or other machine onto which this equipment will be installed.

All P/A products are sold for use only in accordance with our installation and operating instructions which accompany the products. P/A accepts no responsibility for any use or application not in accordance with our instructions, or for any modification or alteration of the product.

Accident-free press operation will result from a well developed, management-sponsored and enforced press safety program. P/A Industries is not responsible for notifying the user of this equipment of further changes in State or Federal laws, construction standards, or changes in P/A designed and built products.



www.pa.com



P/A Industries Inc.

P/A Technology Park
522 Cottage Grove Road
Bloomfield, CT 06002-3191 USA

Telephone: 1-800-243-8306
Worldwide: 1-860-243-8306
Telefax: 1-860-242-4870
E-Mail: sales@pa.com

