



ANCHOR LAMINA INC.

DIE SETS

STANDARD DIE SETS

SPECIAL DIE SETS

BALL BEARING DIE SETS

STEEL PLATE

BLANCHARD GRINDING

DIE MAKERS ACCESSORIES

Complete capabilities to manufacture Plain Bearing and Ball Bearing Die Sets in any style or shape to your specifications – plus a full range of products and services including:

- TORCH CUT PLATE (3/8" TO 13" IN STOCK)
- CNC BURNING
- STRESS RELIEVING FURNACES
- BLANCHARD GRINDING UP TO 144"
- CNC BORING MILLS (120 x 264" CAPACITY)
- BOLSTER PLATES
- WELDMENTS

TOOL MAKERS ACCESSORIES

- LAMINA PINS – BUSHINGS
- BALL BEARING COMPONENTS
- BRONZE PLATED WEAR STRIPS
- WEAR PLATES
- L-GIBS – VEE GIBS
- DIE SPRINGS
- MARSHMELLOW SPRINGS
- NITROGEN SPRINGS
- LAM-CAMS AERIAL AND DIE MOUNT
- NAMMS PRODUCTS

Qualified representatives available to quote your requirements.



ADDITIONAL SERVICES AVAILABLE TO SERVE THE TOOL INDUSTRY



Certificate of Registration

This is to certify that KPMG Quality Registrar has registered the Quality System of

ANCHOR LAMINA INC.
WINDSOR MISSISSAUGA CAMBRIDGE

*to the Quality System Standard
ISO 9002:1994
The Quality System is applicable to*

Manufacture and distribution of die sets, sized steel plate and diemaker accessories and services including special machining and stress relieving

This registration is given subject to the terms and conditions governing the use of the certificate as described in the agreement between KPMG Quality Registrar Inc. and the holder thereof. Registration does not assure the effectiveness of the Quality System or the products or services produced by it.



STANDARD

ALL STEEL DIE SETS

Mild Steel Plate – Stress Relieved
 Lamina Pins – Bronze Plated Clamp Type Bushings

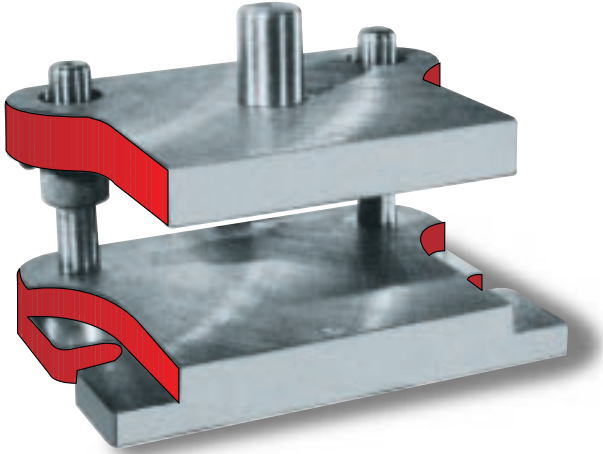

STOCKED FOR PROMPT SHIPMENT

PRICES AVAILABLE ON REQUEST – F.O.B. OUR PLANT
 SALES TAX EXTRA IF APPLICABLE

A	B	C	W	L	P.H.	D.H.	H.	Pin Dia.	Pin Len.	Weight
3	3	3	4 ⁵ / ₈	5 ¹ / ₂	1	1 ¹ / ₄	1 ¹ / ₄	³ / ₄		15
3	4	4	4 ⁵ / ₈	6 ⁵ / ₈	1	1 ¹ / ₄	1 ¹ / ₄	³ / ₄	S P E C I F Y W H E N O R D E R I N G	20
4	4	4	5 ⁵ / ₈	6 ⁵ / ₈	1	1 ¹ / ₄	1 ¹ / ₄	³ / ₄		25
4	6	6	6	9	1 ¹ / ₄	1 ¹ / ₂	1 ¹ / ₄	1		40
4	8	8	6	11	1 ¹ / ₄	1 ¹ / ₂	1 ¹ / ₄	1		50
5	5	5	7	8	1 ¹ / ₄	1 ¹ / ₂	1 ¹ / ₄	1		45
5	7	7	7	10	1 ¹ / ₄	1 ¹ / ₂	1 ¹ / ₄	1		55
5	9	9	7	12	1 ¹ / ₄	1 ¹ / ₂	1 ¹ / ₄	1		65
6	6	6	8	9	1 ¹ / ₄	1 ¹ / ₂	1 ¹ / ₄	1		55
6	8	8	8	11	1 ¹ / ₄	1 ¹ / ₂	1 ¹ / ₄	1		70
6	10	10	8 ¹ / ₄	13 ¹ / ₄	1 ¹ / ₂	1 ³ / ₄	1 ¹ / ₂	1 ¹ / ₄		100
7	7	7	9 ¹ / ₄	10 ¹ / ₄	1 ¹ / ₄	1 ¹ / ₂	1 ¹ / ₂	1 ¹ / ₄	75	
7	9	9	9 ¹ / ₄	12 ¹ / ₄	1 ¹ / ₂	1 ³ / ₄	1 ¹ / ₂	1 ¹ / ₄	105	
8	8	8	10 ¹ / ₄	11 ¹ / ₄	1 ¹ / ₂	1 ³ / ₄	1 ¹ / ₂	1 ¹ / ₄	120	
8	10	10	10 ¹ / ₄	13 ¹ / ₄	1 ¹ / ₂	1 ³ / ₄	1 ¹ / ₂	1 ¹ / ₄	125	

OTHER SIZES AVAILABLE TO YOUR SPECIFICATIONS

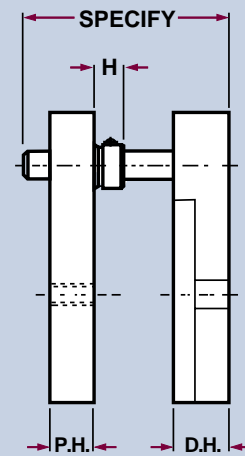
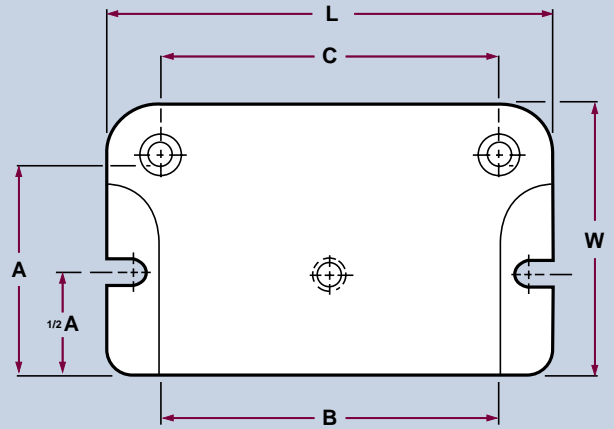

Special thickness can be supplied for an additional set-up charge.

Welded shank available, price on request.

SHANKS AVAILABLE

- 1¹/₂ dia. x 2¹/₈ (1¹/₄-12 NF)
- 2 dia. x 2⁷/₈ (1¹/₄-12 NF)
- 2¹/₂ dia. x 2⁷/₈ (1¹/₂-12 NF)
- 3 dia. x 3 (1¹/₂-12 NF)

When Ordering Specify:

1. Type Standard
2. Dimension A & B
3. Thickness P.H. and D.H.
4. Length of Pins
5. Size and location of Shank if required.
6. Bushings if other than standard.



ANCHOR BACK POST

DIE SETS

Mild Steel Plate – Stress Relieved
Also available in Aluminum

**SPECIAL DIE SETS ARE
MANUFACTURED IN ANY SIZE OR SHAPE
TO YOUR SPECIFICATIONS**

PRICES AVAILABLE ON REQUEST – F.O.B. OUR PLANT
SALES TAX EXTRA IF APPLICABLE

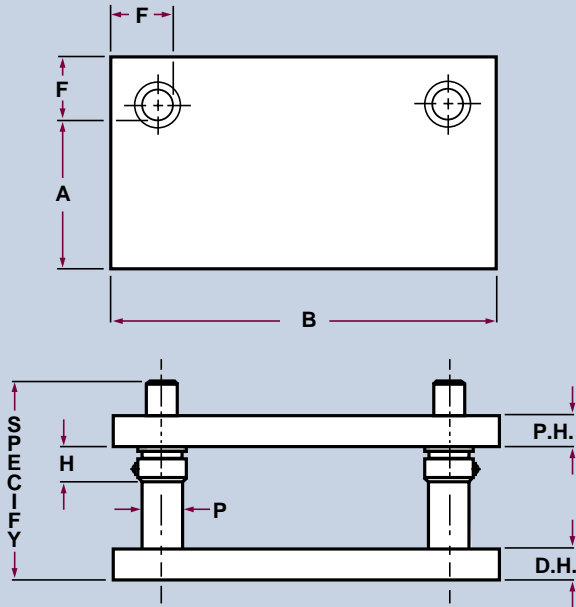

P	1	1 1/4	1 1/2	1 3/4	2	2 1/2	3
F	2	2 1/4	2 1/2	3	3 1/4	3 3/4	4 1/2
H	1 1/4	1 1/2	1 1/2	1 1/2	1 1/2	2	2

SHANKS AVAILABLE

1 1/2 dia. x 2 1/8	(1 1/4-12 NF)
2 dia. x 2 7/8	(1 1/4-12 NF)
2 1/2 dia. x 2 7/8	(1 1/2-12 NF)
3 dia. x 3	(1 1/2-12 NF)

When Ordering Specify:

1. Type B2
2. Dimension A & B
3. Thickness P.H. and D.H.
4. Pin Diameter and Length
5. Size and location of Shank if required.
6. Bushings if other than standard.

		B												
		8	10	12	14	16	18	20	22	24	26	28	30	32
A	6	20	25	30	35	40	45	50	55	60	65	70	75	80
	8	25	30	35	40	50	55	60	70	75	80	85	90	95
	10	30	35	45	50	60	70	75	85	90	95	100	115	120
	12			50	60	70	80	85	95	100	110	120	130	140
	14	1 1/2" PINS			70	80	85	90	105	120	130	140	150	160
	16					85	95	110	120	135	145	155	170	180
	18						110	125	135	145	160	175	185	200
	20				1 3/4" PINS			135	150	165	175	190	205	215
	22								160	175	190	205	220	235
	24									190	205	225	240	255
A	26						2" PINS			220	240	255	275	
	28										255	275	295	
	30											290	310	
	32												335	
	34													
	36										2" PINS			
A	38													
	40													
	42													
	44													
	46													
	48													

Die space sizes are grouped by colour shading with suggested guide pin diameters.

Box numbers indicate the approximate weight of a single steel plate 1" thick.

**TYPE B2 DIE SETS ARE MADE TO ORDER
AND MAY NOT BE RETURNED FOR CREDIT.**

ANCHOR BACK POST

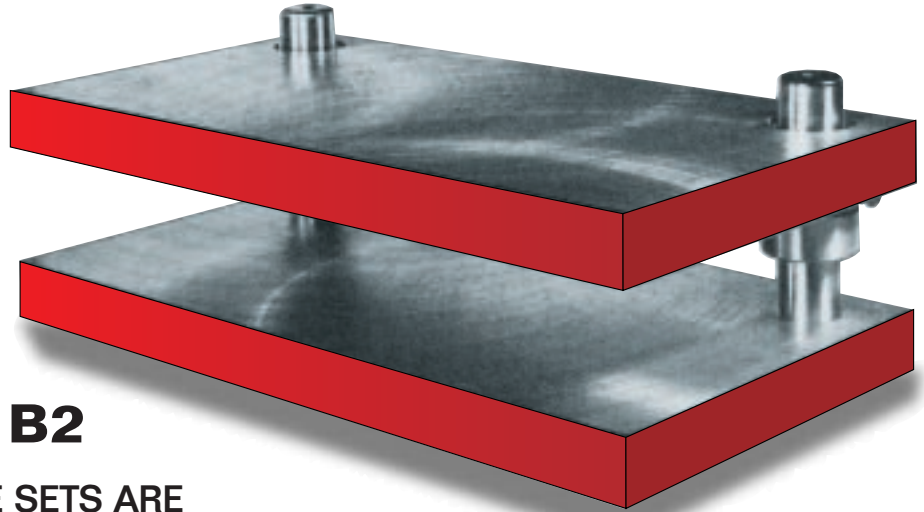

TYPE B2

ANCHOR DIE SETS ARE
EQUIPPED WITH CLAMP TYPE BRONZE
PLATED SHOULDER BUSHINGS.

B										B										B										
34	36	38	40	42	44	46	48	50	52	54	56	58	60	62	64	66	68	70	72	74	76	78	80	82	84					
85	90	95	100	105	115	120	125	130	135	140	145	150	160	170	175	180	185	190	195	200	205	220	230	235	240	6				
110	115	120	130	135	140	150	155	160	170	175	185	190	195	205	210	215	225	230	235	245	250	270	275	280	290	8				
130	140	145	155	165	170	180	185	195	200	210	215	225	230	240	250	255	265	270	280	285	295	315	320	330	340	10				
150	160	170	180	185	195	205	215	225	230	240	250	260	270	275	285	295	305	310	320	340	350	360	370	380		12				
170	180	190	200	210	220	230	240	250	260	270	285	295	305	315	325	335	345	355	365	385	395	405	415	425		14				
190	205	215	225	235	250	260	270	280	295	305	315	325	340	350	360	370	385	395	405	430	440	450	460	475		16				
210	225	235	250	260	275	285	300	310	325	335	350	360	375	395	405	420	435	445	460	470	485	495	510			18				
230	245	260	270	285	300	315	325	340	355	365	380	395	410	430	445	460	475	485	500	515	530	540	555			20				
250	265	280	295	310	325	340	355	375	390	405	420	435	450	465	480	495	515	530	545	560	575	590	605			22				
270	285	305	320	335	350	375	390	405	420	440	455	470	485	505	520	535	550	570	585	600	615	635	650			24				
290	310	325	340	360	375	400	420	435	455	470	490	505	525	540	555	575	590	610	625	645	660	680				26				
310	330	345	365	385	400	425	445	465	485	500	520	540	560	575	595	615	630	650	670	690	705	725				28				
330	350	370	390	415	435	455	475	495	515	535	555	575	595	615	630	650	670	690	710	730	750					30				
355	375	400	420	440	460	480	500	525	545	565	585	605	630	650	670	690	710	735	755	775	795					32				
375	400	420	440	465	485	510	530	555	575	595	620	640	665	685	705	730	750	775	795	820						34				
	420	440	465	490	510	535	560	580	605	630	650	675	700	720	745	770	790	815	840	860						36				
		465	490	515	540	560	585	610	635	660	685	710	735	760	780	805	830	855	880							38				
			510	540	565	590	615	640	665	690	715	745	770	795	820	845	870	895	920							40				
				570	600	625	655	680	710	735	760	790	815	845	870	900	925	955								42				
					625	655	680	710	740	765	795	825	850	880	910	935	965									44				
						680	710	740	770	800	830	860	885	915	945	975										46				
							740	770	800	830	860	890	920	955	985	1015										48				

ANCHOR CENTER POST

DIE SETS

Mild Steel Plate – Stress Relieved
Also available in Aluminum
Two pin sizes are used to prevent reversing.

TYPE C2

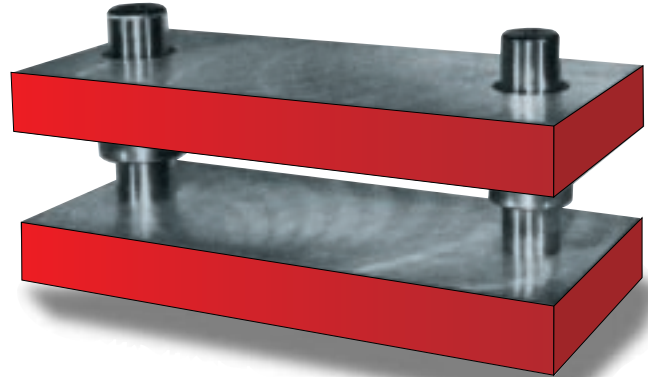

CENTER PINS, TYPE C2

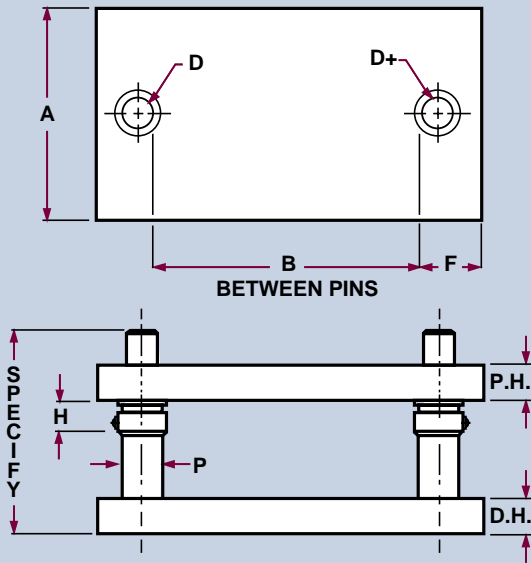

DIAGONAL PINS, TYPE D2

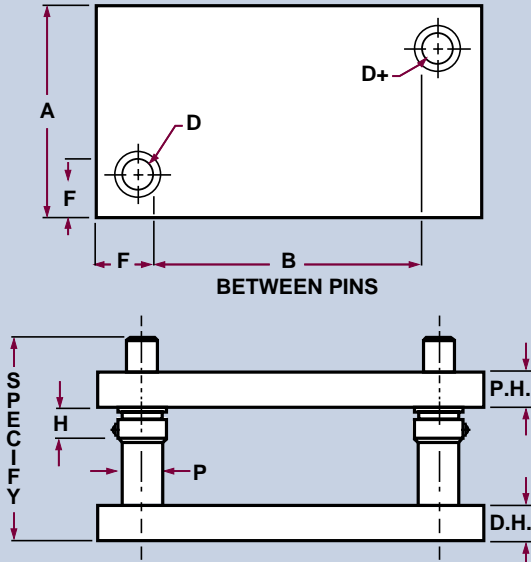

P	1	1 ¹ / ₄	1 ¹ / ₂	1 ³ / ₄	2	2 ¹ / ₂	3
F	2	2 ¹ / ₄	2 ¹ / ₂	3	3 ¹ / ₄	3 ³ / ₄	4 ¹ / ₂
H	1 ¹ / ₄	1 ¹ / ₂	1 ¹ / ₂	1 ¹ / ₂	1 ¹ / ₂	2	2

When Ordering Specify:

1. Type C2 or D2
2. Dimension A & B
3. Thickness P.H. and D.H.
4. Pin Diameter and Length
5. Size and location of Shank if required.
6. Bushings if other than standard.

1¹/₄" & 1¹/₂" PINS

B

	8	10	12	14	16	18	20	22	24	26	28	30	32
	20	25	30	30	35	40	45	50	50	55	60	60	65
	30	35	40	45	50	55	60	65	70	75	80	85	85
		45	50	55	60	70	75	80	85	90	100	105	110
A	12	1 ¹ / ₂ " AND	60	70	75	80	90	95	105	115	120	125	135
	14	1 ³ / ₄ " PINS		80	90	95	105	110	125	130	140	150	160
	16				100	110	125	130	140	150	165	175	180
	18			1 ³ / ₄ " AND		125	140	150	160	175	185	195	205
	20			2" PINS			155	165	180	195	205	215	230
	22							185	200	210	225	240	250
	24								215	230	245	260	275
A	26								250	265	280	295	
	28									285	305	320	
	30											325	340
	32												375
	34												
	36												
A	38												
	40												
	42												
	44												
	46												
	48												

Die space sizes are grouped by colour shading with suggested guide pin diameters.
Box numbers indicate the approximate weight of a single steel plate 1" thick.

TYPE C2 AND D2 DIE SETS ARE MADE TO ORDER AND MAY NOT BE RETURNED FOR CREDIT.

ANCHOR DIAGONAL POST

ANCHOR DIE SETS ARE EQUIPPED WITH CLAMP TYPE BRONZE PLATED SHOULDER BUSHINGS.

TYPE D2

SHANKS AVAILABLE

1 1/2 dia. x 2 1/8 (1 1/4-12 NF)
 2 dia. x 2 7/8 (1 1/4-12 NF)
 2 1/2 dia. x 2 7/8 (1 1/2-12 NF)
 3 dia. x 3 (1 1/2-12 NF)

SPECIAL DIE SETS ARE MANUFACTURED IN ANY SIZE OR SHAPE TO YOUR SPECIFICATIONS

PRICES AVAILABLE ON REQUEST – F.O.B. OUR PLANT SALES TAX EXTRA IF APPLICABLE

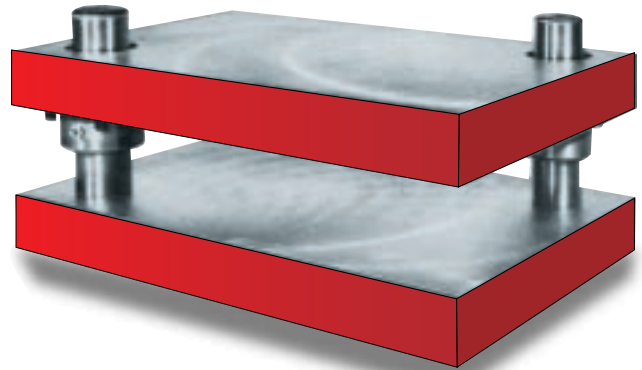

B																				B																				B																													
34	36	38	40	42	44	46	48	50	52	54	56	58	60	62	64	66	68	70	72	74	76		34	36	38	40	42	44	46	48	50	52	54	56	58	60	62	64	66	68	70	72	74	76		34	36	38	40	42	44	46	48	50	52	54	56	58	60	62	64	66	68	70	72	74	76		
70	70	75	80	85	90	90	95	100	100	105	110	115	115	120	125	130	130	135	140	140	145	6																																															
95	100	105	110	115	115	120	125	130	140	140	145	150	155	160	165	170	175	180	185	190	195	8																																															
120	125	130	135	145	150	155	160	165	170	180	185	190	195	200	210	215	220	225	230	235	245	10																																															
145	150	160	165	170	180	185	195	200	205	215	220	230	235	240	250	255	265	270	275	285	290	12																																															
170	175	185	190	200	210	215	225	235	240	250	260	265	275	285	290	300	305	315	325	335		14																																															
190	200	210	220	230	240	250	255	265	275	285	295	305	315	325	330	340	350	360	370	385		16																																															
215	225	235	245	260	270	280	290	300	310	320	330	340	355	370	380	390	400	410	425	435		18																																															
240	250	265	275	285	300	310	320	340	355	365	375	390	400	410	425	435	445	460	470			20																																															
265	275	290	300	315	330	350	360	375	390	400	415	425	440	450	465	480	490	505	515			22																																															
290	300	315	330	345	360	380	395	410	425	435	450	465	480	495	510	520	535	550	565			24																																															
310	325	340	360	375	390	415	430	445	460	475	490	505	520	535	550	565	580	595	610			26																																															
335	350	370	385	400	420	445	460	475	495	510	525	545	560	575	590	610	625	640				28																																															
360	375	395	415	440	460	475	495	510	530	545	565	580	600	615	635	650	670	685				30																																															
395	415	435	450	470	490	510	525	545	565	585	600	620	640	660	675	696	715					32																																															
420	440	460	480	500	520	540	560	580	600	620	640	660	680	700	720	740	760					34																																															
	460	485	510	530	550	570	595	615	635	655	675	700	720	740	760	785	805					36																																															
		515	535	560	580	605	625	650	670	695	715	735	760	780	805	825						38																																															
			565	590	610	635	660	680	705	730	755	775	800	825	845							40																																															
				620	640	665	690	715	740	765	790	815	840	865	890							42																																															
					675	700	725	750	775	800	825	855	880	905								44																																															
						730	760	785	810	840	865	890	920	945								46																																															
							790	820	845	875	905	930	960									48																																															



ANCHOR FOUR POST

DIE SETS

Mild Steel Plate – Stress Relieved
Also available in Aluminum

ONE GUIDE PIN IS OFFSET TO PREVENT ACCIDENTAL REVERSING

SPECIAL DIE SETS ARE MANUFACTURED IN ANY SIZE OR SHAPE TO YOUR SPECIFICATIONS

PRICES AVAILABLE ON REQUEST – F.O.B. OUR PLANT
SALES TAX EXTRA IF APPLICABLE

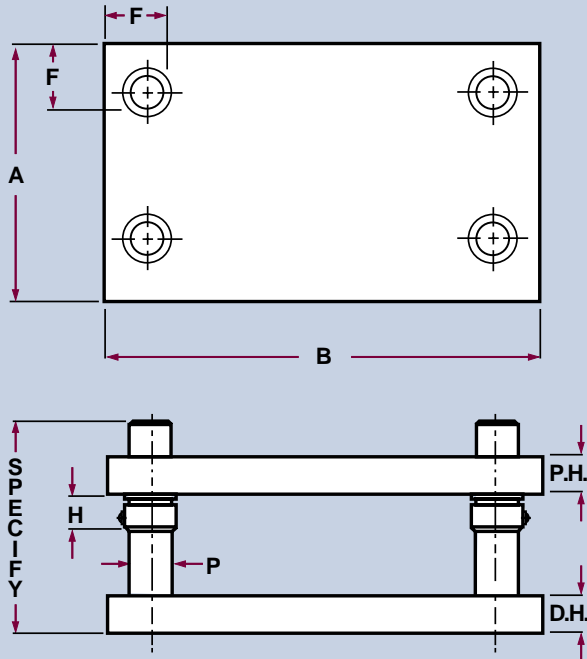

P	1	1 1/4	1 1/2	1 3/4	2	2 1/2	3
F	2	2 1/4	2 1/2	3	3 1/4	3 3/4	4 1/2
H	1 1/4	1 1/2	1 1/2	1 1/2	1 1/2	2	2

SHANKS AVAILABLE

1 1/2 dia. x 2 1/8	(1 1/4-12 NF)
2 dia. x 2 7/8	(1 1/4-12 NF)
2 1/2 dia. x 2 7/8	(1 1/2-12 NF)
3 dia. x 3	(1 1/2-12 NF)

When Ordering Specify:

1. Type R4
2. Dimension A & B
3. Thickness P.H. and D.H.
4. Pin Diameter and Length
5. Size and location of Shank if required.
6. Bushings if other than standard.

	1" PINS				B				1 1/4" PINS				
	10	12	14	16	18	20	22	24	26	28	30	32	34
	6	15	20	25	30	30	35						
	8	25	30	30	35	40	45	50	55	60	65	70	
	10	30	35	40	45	50	60	65	70	75	80	85	95
	12		40	50	55	65	70	75	85	90	100	105	110
A	14			55	65	75	80	90	100	105	115	125	130
	16				75	85	95	105	110	120	130	140	150
	18	1 1/2" PINS			95	105	115	125	135	145	160	170	180
	20					115	130	140	150	165	175	185	200
	22						140	155	165	180	195	205	220
	24							170	180	195	210	225	240
A	26					1 3/4" PINS			200	215	230	245	260
	28									230	245	260	280
	30										265	280	300
	32											300	320
	34										2" PINS		340
	36												
A	38												
	40												
	42												
	44												
	46												
	48												
	50												

R4 DIE SETS ARE MADE TO ORDER AND MAY NOT BE RETURNED FOR CREDIT.

Die space sizes are grouped by colour shading with suggested guide pin diameters.
Box numbers indicate the approximate weight of a single steel plate 1" thick.

ANCHOR FOUR POST

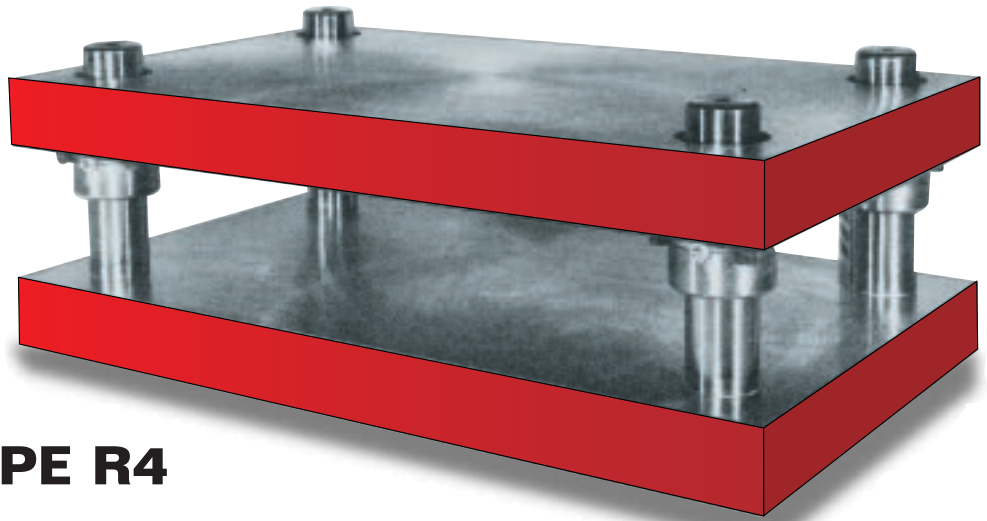

TYPE R4

ANCHOR DIE SETS ARE EQUIPPED WITH CLAMP
TYPE BRONZE PLATED SHOULDER BUSHINGS.

B				B										B										
36	38	40	42	44	46	48	50	52	54	56	58	60	62	64	66	68	70	72	74	76	78	80	82	
																								6
																								8
105	110	115	125	130	135	140	145	150	160	165	170	175	180	185	195	200	205	210	215	220	230	235	240	10
125	135	140	145	155	160	170	175	180	190	195	205	210	215	225	230	240	245	255	260	265	275	280	290	12
145	155	165	170	180	190	195	205	215	220	230	235	245	255	260	270	280	285	295	305	310	320	330	335	14
170	180	185	195	205	215	225	235	245	255	260	270	280	290	300	310	320	330	335	345	355	365	3675	385	16
190	200	210	220	230	240	255	265	275	285	295	305	315	325	335	350	360	370	380	390	400	410	420	430	18
210	220	235	245	255	270	280	295	305	315	330	340	350	365	375	385	400	410	420	435	445	455	470		20
230	245	255	270	285	295	310	320	335	350	360	375	385	400	410	425	440	450	465	475	490	500	515		22
255	265	280	295	310	325	335	350	365	380	395	405	420	435	450	465	480	490	505	520	535	550	560		24
275	290	305	320	335	350	365	380	395	410	425	440	455	470	485	500	520	535	550	565	580	595	610		26
295	310	330	345	360	375	395	410	425	445	460	475	490	510	525	540	555	575	590	605	625	640			28
315	335	350	370	385	405	420	440	455	475	490	510	525	545	560	580	595	615	630	650	670	685			30
335	355	375	395	410	430	450	470	485	505	525	545	560	580	600	620	635	655	675	695	710	730			32
360	380	400	420	440	460	480	500	520	535	555	575	595	615	635	655	675	695	715	735	755				34
380	400	420	445	465	485	505	525	550	570	590	610	630	655	675	695	715	740	760	780	800				36
	425	445	465	490	510	535	555	580	600	625	645	670	690	710	735	755	780	800	825					38
		470	490	515	540	560	585	610	630	655	680	705	725	750	775	795	820	845	865					40
			515	540	565	590	615	640	665	690	715	740	760	785	810	835	860	885						42
				565	595	620	645	670	695	720	745	775	800	825	850	875	900							44
					2 1/2" PINS	620	645	675	700	725	755	780	810	835	860	890	915	945						46
						675	700	730	760	785	815	845	870	900	930	955								48
							730	760	790	820	850	880	910	935	965									50



ANCHOR ECONOLINE

ALL STEEL DIE SETS

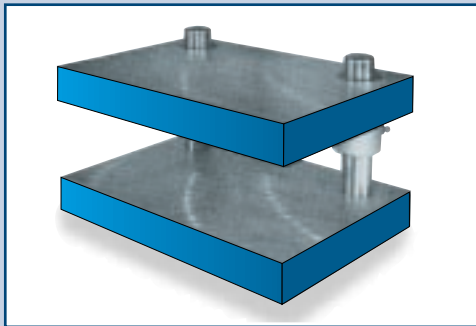

ECONOLINE Die Sets are a high grade commercial die set suitable for most precision requirements.

ECONOLINE Die Sets are completely assembled before shipment.

ECONOLINE Die Sets are equipped with Bronze Plated Press Fit shoulder bushings complete with grease fittings and steel guide pins hardened and ground.

ECONOLINE Die Sets are torch-cut from Prime Plate, completely stress relieved and Blanchard ground.

LENGTH OF GUIDE PINS AVAILABLE:

5 - 5 1/2 - 6 - 6 1/2 - 7 - 7 1/2 or 8" long.
At no extra charge.

Longer lengths available.

"F" Dim. is 2 1/2" with 1 1/2" Pins

SHANKS AVAILABLE

1 1/2 dia. x 2 1/8	(1 1/4-12 NF)
2 dia. x 2 7/8	(1 1/4-12 NF)
2 1/2 dia. x 2 7/8	(1 1/2-12 NF)
3 dia. x 3	(1 1/2-12 NF)

When Ordering Specify:

1. Type ECONOLINE
2. Dimension A & B
3. Thickness P.H. and D.H.
4. Lengths of Pins
5. Size and location of Shank if required.

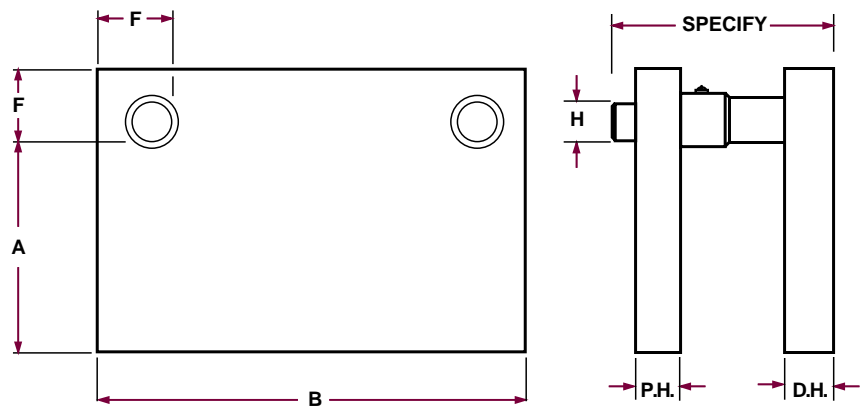

PRICES AVAILABLE ON REQUEST - F.O.B. OUR PLANT SALES TAX EXTRA IF APPLICABLE

ALL SIZES IN STOCK . . . for immediate shipments.

SIZE	PIN	P.H.	D.H.	Weight	P.H.	D.H.	Weight	P.H.	D.H.	Weight	P.H.	D.H.	Weight
A B	Dia.	1 1/2	1 1/2		1 1/2	2		2	1 1/2		2	2	
6 x 8	1 1/2	150-150		60	150-200	70		200-150	70		200-200		80
6 x 10	1 1/2	150-150		75	150-200	90		200-150	90		200-200		100
6 x 12	1 1/2	150-150		90	150-200	105		200-150	105		200-200		120
6 x 14	1 1/2	150-150		105	150-200	120		200-150	120		200-200		140
6 x 18	1 1/2	150-150		135	150-200	160		200-150	160		200-200		180
8 x 8	1 1/2	150-150		75	150-200	85		200-150	85		200-200		100
8 x 10	1 1/2	150-150		95	150-200	110		200-150	110		200-200		125
8 x 12	1 1/2	150-150		110	150-200	130		200-150	130		200-200		150
8 x 14	1 1/2	150-150		130	150-200	150		200-150	150		200-200		175
8 x 18	1 1/2	150-150		170	150-200	195		200-150	195		200-200		220
10 x 10	1 1/2	150-150		110	150-200	125		200-150	125		200-200		150
10 x 12	1 1/2	150-150		135	150-200	155		200-150	155		200-200		180
10 x 14	1 1/2	150-150		155	150-200	180		200-150	180		200-200		205
10 x 18	1 1/2	150-150		205	150-200	235		200-150	235		200-200		270
12 x 12	1 1/2	150-150		160	150-200	185		200-150	185		200-200		210
12 x 14	1 1/2	150-150		185	150-200	215		200-150	215		200-200		245
12 x 18	1 1/2	150-150		235	150-200	275		200-150	275		200-200		315
14 x 14	1 1/2	150-150		210	150-200	240		200-150	240		200-200		275
14 x 18	1 1/2	150-150		270	150-200	310		200-150	310		200-200		355

ANCHOR ECONOMY

ALL STEEL DIE SETS

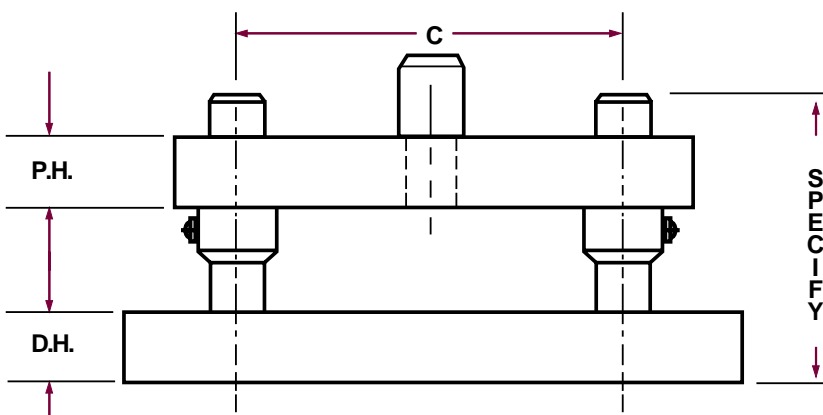
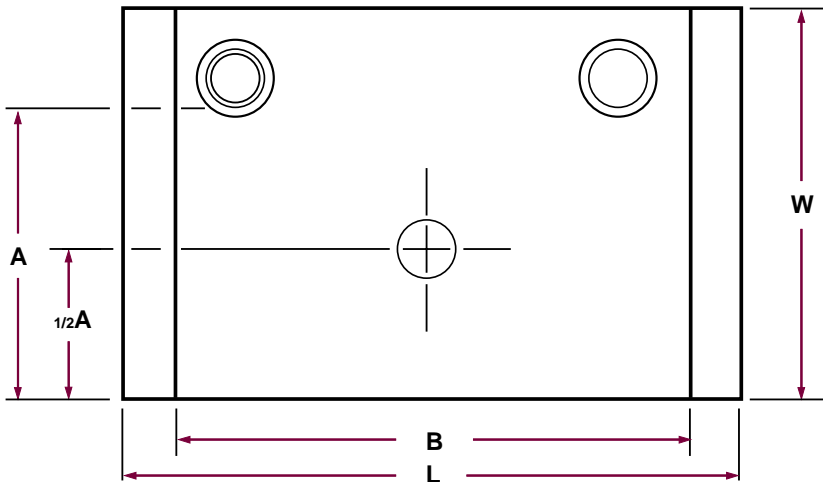

PRICES AVAILABLE ON REQUEST – F.O.B. OUR PLANT SALES TAX
EXTRA IF APPLICABLE

ALL SIZES IN STOCK . . . for immediate shipment.

A	B	C	L	W	P.H.	D.H.	Pin Dia.	Pin Length	Price	Approx. Weight
4	6	3 1/2	8	5 3/4	1 1/4	1 1/4	1	S P E C I F Y	O N R E Q U E S T	35 lbs.
6	6	3 1/2	8	7 3/4	1 1/4	1 1/4	1			45 lbs.
6	8	5 1/2	10	7 3/4	1 1/4	1 1/4	1			55 lbs.

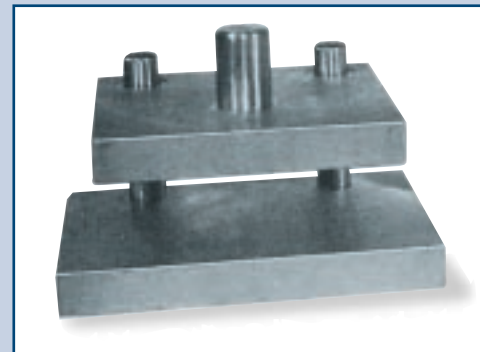

ECONOMY DIE SETS . . . Presently utilized in numerous applications within the Die Making Industry.

Lamina Guide Pins . . . Hardened and ground.

Lamina Bronze Plated Bushings . . . Press Fit Type with grease fitting.

Torch cut from Prime Steel Plate, Blanchard ground and bored (not reamed) to produce an accurate, economical Die Set.

LENGTH OF GUIDE PINS AVAILABLE:

5 – 5 1/2 – 6 – 6 1/2 – 7 or 8" long.
At no extra charge.

SHANKS AVAILABLE

1 1/2 dia. x 2 1/8 (1 1/4-12 NF)
2 dia. x 2 7/8 (1 1/4-12 NF)

When Ordering Specify:

1. Type Economy
2. Dimension A & B
3. Length of Pins
4. Shank Diameter if required



NORTH AMERICAN LOCATIONS

CANADA

Windsor	Toronto	Cambridge	Montreal
(519) 966-4431	(905) 274-3448	(519) 740-3060	(514) 525-5560

U.S.A.

Madison Heights, MI	Cincinnati, Ohio	Cleveland, Ohio	Nashville, TN
	1-800-543-3790		

Cheshire, Conn.	Grand Rapids, MI	Milwaukee, WI
1-800-950-3999	1-888-526-2467	

EUROPEAN LOCATIONS (EOC Normalien Group)

GERMANY

Lüdenscheid	Mahlberg	Grüna bei Chemnitz
-------------	----------	--------------------

