

# AIR PUNCH PRESSES



## MODELS:

No. 25

No. 30

No. 35

No. 45

No. 50



# AIR PUNCH PRESSES

## Punch Tools - Air Punch Presses

**Let us introduce you to a better way to punch, form, countersink and run single station or progressive dies.**



Punch Tools Air Punch Presses are portable, safe and virtually maintenance free. Versatile and variable tonnage with the unique ability to be able to shift the load centre to where the work needs to be done.

Our Air Punch Presses do not need any special hook up and can be running within 5 minutes of arriving at your shop. You just need to hook it up to air, no need for special electrical connections or regulatory approvals. Just plug her in and go.

Bring the Air Punch Press to the job rather than having to accommodate the place in the shop you put the press in 2 years ago which no longer works for you. Our Air Punch Presses are all on wheels and can be relocated easily to accommodate that new job where you have processing 20 ft long extrusions.

Feed from front, back, left, or right it doesn't matter, whichever way works best — Air Punch Presses will work with you.

Punch Tools Air Punch Presses are virtually maintenance free, just a little oil in the lubricator once in a while and they will run forever.

Air Punch Presses are safe — the standard is a foot pedal that when released the ram returns automatically. As an option you can have anti tie down palm buttons, — all shielding of tooling is the responsibility of the customer.

Our Air Punch Presses come in a variety of sizes and tonnage from single cylinder 2-1/2 ton model to dual cylinder 100 tons.

Each Punch Tools Air Punch Press comes with a one year warranty.

## Installation Instructions

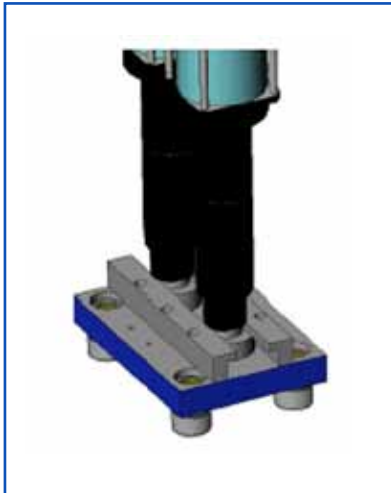

Depending on the model you may have up to three cylinders installed on the press.

Each cylinder can be positioned individually along the top railing frame of the press. This allows you to find the three load center of any specific tool. The lower railings or frame has 1/2" NC threaded holes at every three inches to mount and secure the die set to the press.

Some models have double acting cylinders that power down, power up. In this case you use die set mount gibs for the top of the die set and a special striker head for the cylinder(s). They are standard for these models. For single acting models power down only. Springs must be installed to accommodate the return stroke.

The design allows easy slide on installation of the tool, where no bolts required to secure the top die set.

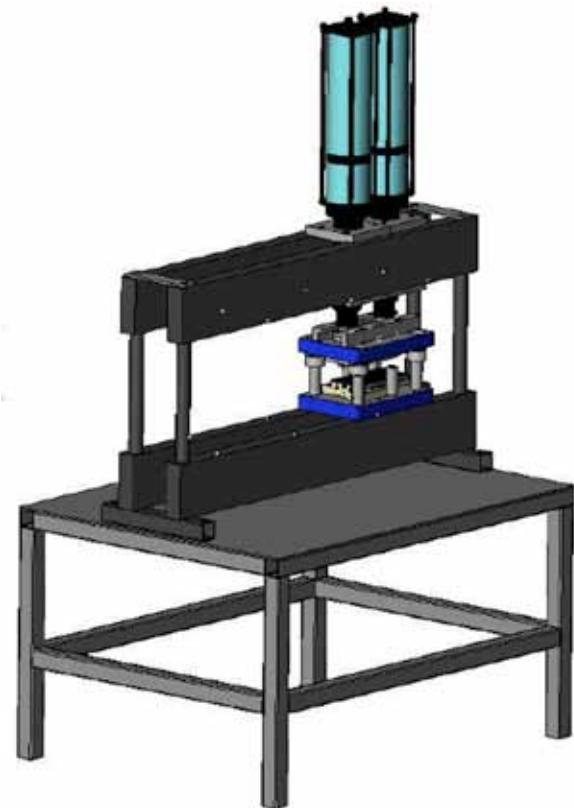

### TO INSTALL A DIE IS AS EASY AS 1, 2, 3!

1. Disconnect the quick air connector to power the press down.
2. Put the tool onto the lower railings. When mount gibs are present, slide the tool onto the striker head(s).
3. Secure the bottom die set to the lower railing with two or four 1/2" NC cap screws. Connect the quick air connector to power up the press.

# AIR PUNCH PRESSES

## Specifications

### PUNCH TOOLS - AIR PUNCH PRESSES

<b>TABLE DIMENSIONS</b>	<b>W: 33" x L: 36" or L: 48" x H: 32"</b>
<b>FRAME DIMENSIONS</b>	<b>W: 8.5", BW: 4.5", L: 33" or 48", H: 13.1", R: 6", T: 2"</b>
<b>PILLAR</b>	<b>1.5" diameter</b>
<b>TOTAL HEIGHT</b>	<b>81 lb</b> (from floor to top of cylinder)
<b>WEIGHT</b>	<b>1400 lb</b> (table, frame and two cylinders)
<b>OPERATING AIR PRESSURE</b>	<b>120 PSI</b> (dry air intake required)
<b>NUMBER OF CYLINDERS</b>	<b>Up to 3</b>
<b>TONNAGE OF EACH CYLINDER</b>	<b>2.5 - 40 tons</b> (depending on model) Cylinders are available in single acting or double acting style. There are 8 types of single acting and 6 types of double acting cylinders. The 14 cylinder types come with different over all stroke, power stroke, or tonnage.
<b>MAXIMUM OVERALL STROKE</b>	<b>Up to 4</b>
<b>POWER STROKE</b>	<b>1/8" - 1-1/2"</b> (depending on model)

The press' or pillars height must be specified if different than standard or tooling specifications required to determine the height.

Required tonnage and or the number of cylinders must be specified or tooling and or production specifications required to determine power requirement.

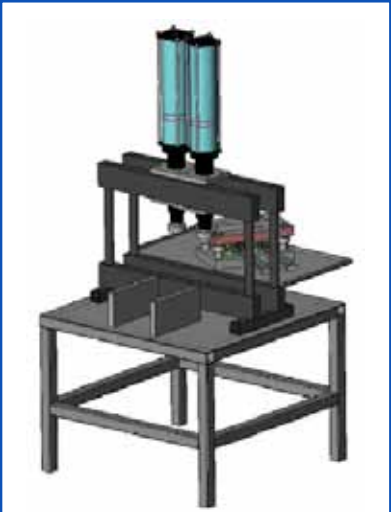
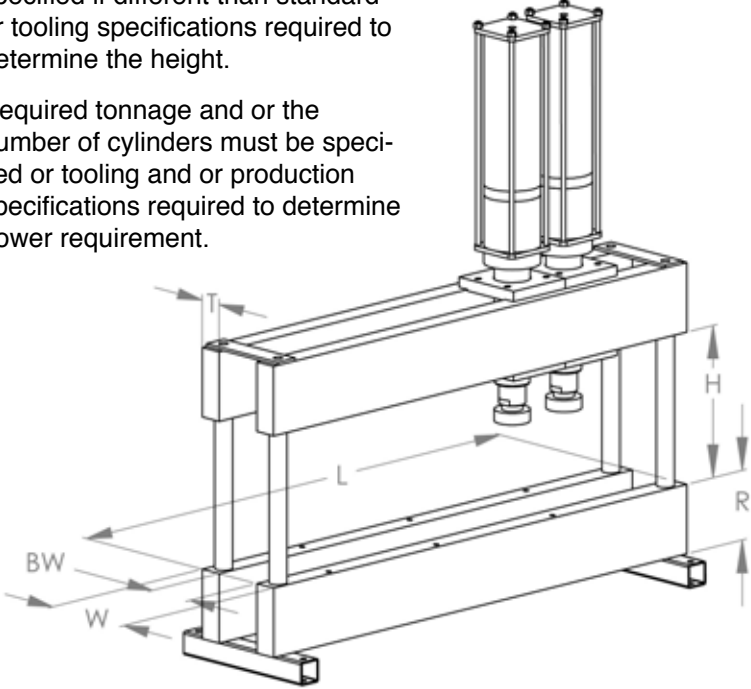

#### Options

- Front loading bars (for tool installation).
- Striker head(s) and die set mount gibs (adaptor plate maybe pattern of tooling).
- Rear tool storage platform.
- Anti tie down palm buttons.
- Non-contact electronic anti tie down palm buttons
- Accumulator tank (depend of your air consumption).

## AIR PUNCH PRESSES



### Selection\*

#### PUNCH TOOLS - AIR PUNCH PRESSES

##### Standard Model No. 25

<b>Press length</b>	33"
<b>Tonnage</b>	7.5 ton (single acting)
<b>Overall Stroke</b>	5/8"
<b>Power Stroke</b>	9/32"
<b>No. of Cylinders</b>	1

##### Standard Model No. 40

<b>Press Length</b>	48"
<b>Total Tonnage</b>	22.5 ton (single acting)
<b>Over all Stroke</b>	5/8"
<b>Power Stroke</b>	9/32"
<b>No. of Cylinders</b>	3

##### Standard Model No. 30

<b>Press Length</b>	33.0
<b>Total Tonnage</b>	15 ton (single acting)
<b>Overall Stroke</b>	2"
<b>Power Stroke</b>	1/2"
<b>No. of Cylinders</b>	2

##### Standard Model No. 45

<b>Press Length</b>	48"
<b>Total Tonnage</b>	22.5 ton (single acting)
<b>Overall Stroke</b>	2"
<b>Power Stroke</b>	1/2"
<b>No. of Cylinders</b>	3

##### Standard Model No. 35

<b>Press Length</b>	33"
<b>Total Tonnage</b>	12.5 ton (double acting)
<b>Overall Stroke</b>	3 1/4"
<b>Power Stroke</b>	1/2"
<b>No. of Cylinders</b>	1

##### Standard Model No. 50

<b>Press Length</b>	48"
<b>Total Tonnage</b>	25 ton (double acting)
<b>Overall Stroke</b>	3 1/4"
<b>Power Stroke</b>	1/2"
<b>No. of Cylinders</b>	2

\*Custom models are available based on your specifications.

## Contact Us

**PTI PUNCH TOOLS INC.**  
11-211 Schoolhouse Street  
Coquitlam, BC  
V3K 4X9  
Canada

**PHONE:** 604.521.6444  
**FAX:** 604.521.3143  
**TOLL FREE PHONE:** 1.800.668.4996  
**TOLL FREE FAX:** 1.800.99.PUNCH  
**EMAIL:** sales@punchtools.com

## Component - MULTICYL

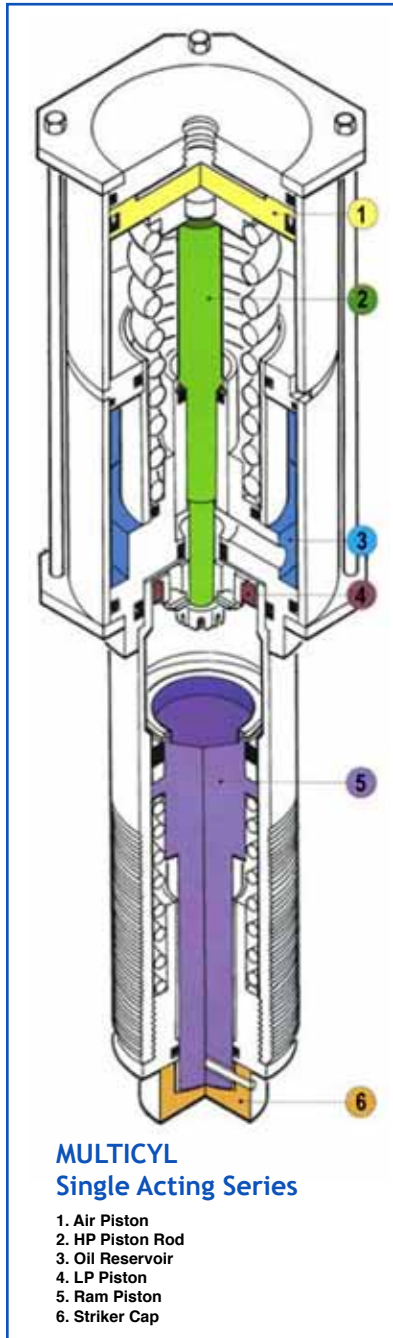

### Is it Important to Know How Multicyl Works?

Not really. Our patented design is like a car engine, internally it is quite complicated but to the user it's very simple. You just put air in one end using a simple air valve and then you get hydraulic power out of the other end of the cylinder.

### What is the Patented Principle?

Known as the 'flow-by' principle it allows the two stage pressure intensifier to self-adjust anywhere on the overall stroke. This means the cylinder will stall when it meets resistance greater than the force on the advance stroke.

### What is the Benefit of a Two Stage, Self Adjusting Stroke?

For the user there are several benefits: simple air controls; lower air consumption as the power is only produced when you need it. Also there is no need to set the tooling to a precise height (as would be necessary in a mechanical press) as the hydraulic action simply "bottoms out" whenever the resistance is greater.

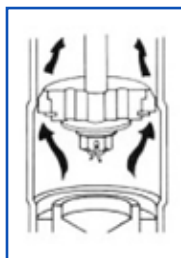

### What Happens Inside the Cylinder During the 'Flow-By' Action?

The ram advances using the 'dashpot' principle until it meets resistance. Enstrapped oil begins to 'flow-by' the low pressure piston by means of precisely controlled clearances as the piston rod is allowed to continue.



## Component - MULTICYL

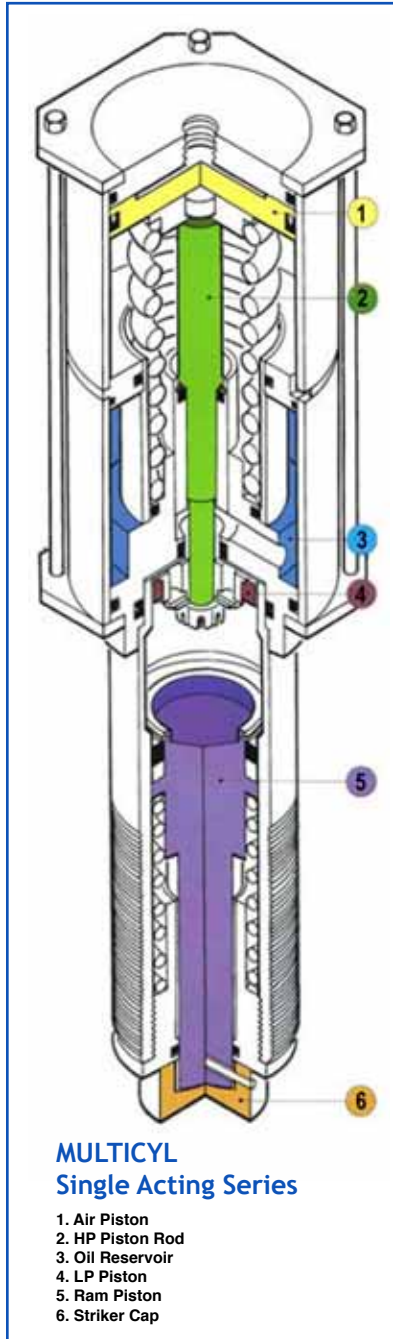

### Spherical Pivot Point (MC & XL Series)

The ram piston and striker cap have a spherical pivot point designed to prevent internal side loading. This feature reduces internal wear on seals and bearings and compensates for out of parallel tool conditions. A roll pin allows the striker cap to float and is designed to shear in extreme conditions. Small tools may be mounted upon the end of the spring returned ram piston.

### The 'Flow-By' Self Adjusting Stroke

Low-pressure (LP) advance stroke. As air pressure is applied to the air piston the HP piston assembly advances. The LP piston valve immediately closes and the ram continues to advance in a full linear fashion until resistance is encountered. There upon LP stroke is dissipated by hydraulic 'flow-by' principle which permits the air cylinder to continue its advance while the ram remains stationary until the HP stage is reached.

High Pressure (HP) power stroke. The HP piston rod seals the high-pressure chamber. The increased diameter of the HP chamber renders the LP piston powerless. This allows the oil to flow freely within the HP chamber as the LP piston advances. The force on the ram is increased due to the pressure being multiplied by the ratio between the areas of the air piston and the area of the ram piston.

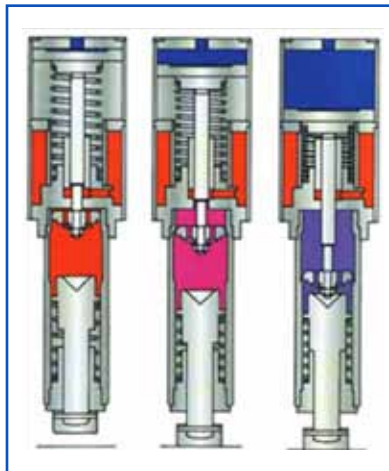

On the return stroke air is exhausted; LP valve immediately opens... allowing oil to flow directly through the piston. Springs return LP piston assembly and arm to 'rest' position.

## Maintenance

This equipment has two major components or units:

### 1. PRESS FRAME

- The press frame requires no maintenance.

### 2. AIR CYLINDER(S) AND ITS COMPONENTS

- The air cylinder(s) has a self lubricating air lubricator that shall be filled with air line oil to provide lubrication for the air cylinder(s).
- The air cylinder(s) operate with 120 PSI and require dry air.
- The air cylinder has a long life expectancy before any maintenance required. At such event a replacement seal kit is available, as well as oil (Telus 32 non foaming) that is inside the cylinder.

## Safety Hazards

- Always disconnect the air supply when installing or removing a tool from the press. The failure to do so may cause bodily harm by accidental actuation of the air cylinder(s).
- Always disconnect the air supply when the press not in use.
- Do not exceed 125 PSI air intake to the cylinder(s).
- When ever possible use an anti tie down operating system that requires the operator to use both hands at the same time to actuate the press. Many accidents caused by the operator reaching inside the tooling area just before actuating the cylinders.
- Install safety guards around your tool to prevent accidents mentioned above.
- Always wear eye protection, ear protection and steel toe safety foot wear.
- For removing small articles from inside the tooling area, use tweezers, pliers, etc.
- Always lock the wheels of the press to keep it at the same position while in use.
- When heavy tools to be installed or removed use a fork lift or other equipment. As an option, the press can be installed with loading bars.